

Porsche Sprint Challenge Iberica

Technical Regulations 2025⁶

PORSCHE 911 GT 3 Cup (Type 991.1 and 991.2)

Name of the Series: Porsche Sprint Challenge Ibérica

Status of the Events: Spanish National Status

Riscos & Trajetorias, Lda hereinafter referred to as P21 Motorsport, hereinafter called the Series organiser, is promoting the Porsche Sprint Challenge Ibérica, hereafter called the PSCI.

The Porsche Sprint Challenge Ibérica is registered as a by the RFEDA (ASN) approved national series.

Organization Riscos e Trajetóris, Lda (hereinafter referred to as P21 Motorsport)
DNA Cascais Cruz da Popa Alcabideche
2645-117 Alcabideche
T: + 351 21 4822240

Contact: José Monroy - Series Manager
Mobile: + 351 916629351
Email: info@p21motorsport.com
Home page: www.porschesprinenchallengeiberica.com

A - Foreword



The Porsche Sprint Challenge Ibérica (PSCI) is a series that gives the opportunity to the Competitors to compete with Porsche 911 GT3 Cup (991) Type 911.1 and 911.2, built in the years as specified. All Cars need to be in the specification such as they left the factory, except when this is clearly allowed by these Regulations. If at any time a team is in doubt about their Car's legality, either because of after-market modifications made to the Car in its history or because they have fitted original parts sold some time after the production of their specific Car, then they are encouraged to have the Car checked by the Series Technical Manager.

B - Chapter subdivisions

The hierarchy of the chapters is shown in the example underneath.

C - Source of spare parts catalogues

All spare parts required by a competitor must be purchased directly from P21 Motorsport

Spare parts catalogues, manuals, technical info's, etc:

Porsche:

PMRSI (motorsport.porsche.de) => Registration form included with every new Car

Porsche Centre

P21 Motorsport

Further applications: tech@porschessprintchallenge.es

P21 MOTORSPORT - technical department

Rua das Fisgas 442 Armazém 1 - 2645-117 Alcabideche

Phone: + 351 21 4822240

Contact: Dinis Mota

Email: tech@porschessprintchallenge.es

Sales P21 Motorsport Series parts & Equipment:

Rua das Fisgas 442 Armazém 1 - 2645-117 Alcabideche

Contact: Dinis Mota - Phone: + 351 21 4822240

Email: logistics@p21motorsport.com

Official Michelin Tyre Supplier:

Neumáticos Álvarez

Contact: Mr. David Rico

Email: david@neumaticosalvarez.com.

www.neumaticosalvarez.com

D - Definitions

PSCI Porsche Sprint Challenge Iberica as the organiser of the Event

TR	Technical Regulations
Team	The entrant and entrant personnel
MY	Model Year, indicates the model version
Gauge block	A calibrated tool with specific dimension, which are not variable
PPN	Porsche part number
✕	Mandatory rework

E - Part numbers Porsche

In the Porsche Motorsport catalogue of the concerning Car is indicated if the part is a Motorsport or a road part.

Technical Regulations

1 - Technical Series Regulations

1.1 - Summary of the eligible categories /classes

The Porsche Sprint Challenge Ibérica is a one-make Series with group/ Categories classification.

Only cars of the type/model Porsche 911 GT3 Cup, type 991 1 (a special series produced by Porsche AG), of the model year 2016 (see following General vehicle description) and model years 2015, 2014 as well as 2013 taking into account the required modifications (see Attachment 1) and the type/model Porsche 911 GT3 Cup, type 991 2 (a special series produced by Porsche AG), of the model year 2017, 2018 and 2019 which fully comply with these Regulations are eligible to participate.

Certain special parts used in the Porsche 911 GT3 Cup Type 99.1 and 991.2 cannot be obtained via the Porsche dealer organisation but instead can only be obtained from the Motorsport Parts Sales Department at Porsche AG, Weissach.

The cars must meet the technical specifications of these Regulations and Appendix J of the International Sporting Code in full and must possess a valid and registered RFEDA car pass or the corresponding document of another ASN associated to the FIA.

1.2 - Principles of the Technical Regulations

In accordance with:

X	Art. 251 and 277 (Group EII-SH) of Appendix J (FIA ISC)
X	General provisions, definitions and clarifications regarding the technical regulations (RFEDA)
X	These Technical Regulations and their Annexes
X	Technical manuals of the eligible cars
X	Technical information of Dr. Ing. h.c. F. Porsche AG
X	Software information of Dr. Ing. h.c. F. Porsche AG
X	Spare parts catalogues of the eligible cars

The Promoter reserves the right to supplement the presented regulations by bulletins if required.

Should there be any discrepancy between the provisions of these Technical Regulation and any relevant Technical Manual, Technical Information, Software Information or Parts Catalogue, then these Technical Regulations will take precedence.

For Software Information, only the version decided by the Promoter is permitted. Without info, only the latest version released. Setups (based on the permitted version)

1.3 - General/preamble

Everything that is not expressly permitted in these Regulations is prohibited. Permitted modifications must not result in any illegal modifications or infringements of the Regulations.

Any addition or removal of material, heat treatment or coating to alter the properties of a part or component and/or its dimensions is forbidden.

Mounting a part in a different way or location than the original delivery condition is forbidden.

1.4 - Driver equipment

Driver equipment must be worn correctly at all times whilst the Driver is seated in the car in the Pre-Grid area, the pit lane or on the track. It is compulsory to wear overalls in compliance with the FIA 8856-2000 or FIA 8856-2018 standard as well as underwear (with long sleeves and legs), balaclava, socks, shoes and gloves in compliance with FIA Regulations.

Furthermore, wearing a helmet including "HANS clips" in accordance with FIA regulations (Attachment L to the ISC) and use of a head restraint (e. g. HANS) is compulsory.

1.4.1 - Frontal Head Restraint System (FHR; HANS® or comparable system)

The use of an FIA-approved head restraint in compliance with FIA list No. 29 is compulsory for all classification rounds and events within the Series as well as for all races outside the Series which are organised according to these Regulations.

Responsibility for the necessary modifications to the driver's equipment in order to enable use of such a system and installation of same in the car in compliance with the manufacturer's instructions lies solely with the participant. The relevant manufacturer's certificate is to be presented during Technical Scrutineering.

1.4.2 - Drinking system

A drinking system without an electric pump may be used. Prior to installation it must be approved by the Technical Scrutineers.

This system may be filled during Pre-Grid procedure under the supervision of the Technical Scrutineers.

1.4.3 - Cooling system

A cooling system with cooling vest may be used. Prior to installation it must be approved by the Technical Scrutineers. The installation according to the manufacturer's instructions is the sole responsibility of the participant.

1.5 - General Regulations

1.5.1 - Permitted modifications and installations

The only work which is permitted to be carried out on the cars is that necessary for its normal servicing, or for the replacement of parts worn through use or accident.

The limits of the modifications and installations permitted are specified hereinafter. Any part worn through use or accident may only be replaced by identical Porsche Genuine Parts that are assigned to the eligible cars in compliance with Item 2.1.

The Porsche Genuine Parts are specified in the valid spare parts catalogue in each case. The use of components manufactured by Porsche AG for other groups of cars (e.g. Porsche road cars) is also prohibited.

The use of any items described as "optional" in the parts catalogue is prohibited, if their use is not specifically permitted by these technical regulations.

Throughout the car, the standard fastening components such as nuts, bolts, washers, lock washers, spring washers and splint pins must only be replaced by Porsche Genuine Parts.

The service and replacement intervals and adjustment values specified by Dr. Ing. h.c. F. Porsche AG (see Technical Manual) are to be observed.

The Series Organiser may permit modifications that do not correspond to the series production status on all or individual cars, providing these do not permit a competitive advantage (e.g. for the attachment of cameras; radio installations, etc.). The competitor must make written application to the PSCI Organiser and receive written authorisation before making any such modification

1.6 - Minimum weights and ballast will be changed and supplemented as follows

It is the competitor's responsibility to ensure that at all times during the event the mandatory minimum combined weight of the car + Driver is reached. The mandatory minimum combined weight is:

991.1	1.305 kgs
991.2	1.320 kg

is the sum of the minimum weight of the car and the minimum Driver weight.

- the weight of the car with empty fuel tank;
- the weight of the inboard camera
- the weight of the ballast holding plate and the installed additional weights (excluding Driver equalization weight);
- the weight of the Driver;
- the weight of the personal equipment of the Driver as it is in the car at the time when the weighing is ordered;
- the Driver equalization weight if applicable.

The checking of the weights of the cars and Drivers will be conducted on the official scale which will be located in the PSCI Technical Scrutineering tent or in an alternative designated place. This is also the weighing area. In addition, Drivers may be weighed on a separate weighing scale either in the weighing area or in a different location.

The official scale and any other driver weighing scale will be checked annually and calibrated by a certificated Laboratory.

1.6.1 - Ballast

The installation of ballast is permitted. Only original Porsche ballast components must be used. These must be installed in the provided holders at the position of the passenger’s seat in accordance with the illustration in Attachment 1. No other ballast weights or location are permitted.

The components of the ballast weights are identified by spare part numbers (part numbers: 997.504.848.00 / 997.504.848.01 / 997.504.848.02). or 991.504.848.00 / 991.504.848.01 / 991.504.848.02 or 9F1801141, 9F1801141A, 9F1801141B.

Equalization weight must be protected with items 991.504.865.9B, 9F1801575 and 991.504.852.9B, WHS001903.

1.6.2 - Base plate auxiliary weight

In addition to the original part, base plates with part numbers 991.504.847.7A/B and 991.504.847.9B are permitted to be used. If the original base plate does not contain the necessary holes for the mounting positions as indicated in these regulations, they can be added after consultation with the Technical Scrutineers. The mounting holes can only be added in the necessary positions to satisfy the requirements of these regulations.

1.6.3 - Minimum Car weight

At no time during an event is the car weight allowed to be less than the mandatory minimum weight.

991.1	1.225 kgs
991.2	1.235 kg

and consists of:

- the weight of the car with empty fuel tank;
- the weight of the inboard camera (surveillance camera and/or official TV camera - if installed), the radio system (if installed) and the marshalling system approved by the Promoter;
- the weight of the ballast holding plate and the installed additional weights (excluding Driver equalization weight);
- the weight of the drinkin system and the equipment for Driver’s cooling vests installed to the base plate auxiliary weight (if any);
- the weight of any additional parts or systems required by the Promotor to be fitted in accordance with Art. 1.1.
- the Ballast Holding Plate and the installed additional weights (excluding Driver equalization weight).

The minimum car weight must also be observed when the levels of operating liquids are under minimum level.

1.6.4 - Minimum Driver weight

The minimum weight of the driver is

991.1	80 kgs
991.2	85 kg

and consists of:

- weight of the Driver;
- the weight of the compulsory personal equipment of the driver (Article 1);
- the Driver equalization weight if applicable

It is the Competitor's responsibility to ensure that the sum of the installed equalisation weight plus the Driver's actual weight (including his personal equipment) achieves or exceeds the minimum Driver weight at all times.

1.6.5 - Determining the total weight of the driver and car

The Technical Scrutineers may in their absolute discretion decide to weigh the car and driver separately or in combination.

If the car and the Driver (together with all driver equipment) are weighed in combination, the weight plus 2.0 kg of weighing tolerance shall be added and the product shall be referenced against the mandatory minimum combined weight, which must be reached.

If the car and the Driver (together with all driver equipment) are weighed separately on the official scale, the two weights plus 3,0 kg of weighing tolerance for the car and 1,5 kg of weighing tolerance for the Driver weight shall be added and the product shall be referenced against the mandatory minimum combined weight, which must be reached.

Prior to weighing a car, the Technical Scrutineers shall remove the remaining fuel from the fuel tank.

1.6.6 - Weight changes during qualifying and races

During the qualifying sessions and races, the weight of the car can only be altered by:

- Changing from slick to wet tyres or vice versa;
- Consumption of used materials and fluids;
- Damage on the car due to an accident.

On the way from the circuit to the "Parc Fermé" and in the "Parc Fermé" itself, and on the way to the post-race Technical Scrutineering under no circumstances is weight permitted to be added to the car or the Driver.

1.6.7 - Verification of the minimum weights by the Entrants on the official scale

Competitors have the opportunity to check the weight of their cars and drivers during the event on the official scale with the permission of the Technical Scrutineers.

Only the measurements recorded by the Technical Scrutineers shall be deemed accurate for the purposes of compliance with the regulations.

1.6.8 - Personal protective Driver equipment during weighing

During the weigh-in, each driver must wear his complete driver apparel as set out in Annex L, Chapter III of the ISC, plus the mandatory head restraint system.

1.6.9 - Weighing of cars

The cars are weighed as follows:

- Weighing of cars is carried out regularly on the official scale.
- During the free practice and qualifying, weighing can also be done by the Technical Scrutineers on the scale of P21Motorsport, which is at a fixed location in the pit lane. Any differences between these scales are taken into account by the Technical Scrutineers.
- During the qualifying, weighing can also be done by the Technical Scrutineers on the scale of P21Motorsport, which is at a fixed garage and accessible by the pit lane. Any differences between these scales are taken into account by the Technical Scrutineers. If the weighing on the P21Motorsport scale indicates that the car in question might be found underweight on the official scale, this car, the driver and his/her protective equipment must again be weighed on the official scale which is the only result to be taken into consideration and to be binding.

- If a Driver is given the signal that his/her car has been selected for weighing, he/she must take the shortest route possible to the weighing area/P21Motorsport scale and turn off the engine.
- The driver or a team member will receive written confirmation of the measured weights. During weighing the driver is not permitted in any way to influence the weighing result.

Any appeal against the observed weight must be immediately submitted to the Technical Scrutineers after receiving the report.

If a car cannot reach the weighing area under its own power, it must be brought to the weighing area solely by marshals. If this is not possible, then the Technical Scrutineers can assign other persons for this purpose.

1.6.10 - Leaving the weighing area

Without the consent of the Technical Scrutineers, the Driver is not permitted to leave the weighing area and the car is not allowed to be removed.

1.6.11 - Weighing after breakdown and car remaining on circuit during qualifying and race

If a car breaks down during the qualifying sessions or the races and the driver leaves his car, if his weight needs to be determined he must go directly to the weighing area.

1.6.12 - Determining the driver weights

After qualifying's and races, all drivers must go immediately and on a direct route from the Parc Fermé to the weighing area to determine their weight.

Drivers who are approached by the TV partner for an interview may interrupt their walk to the weighing area for the duration of the interview.

Drivers who are approached by the TV partner for an interview may interrupt their walk to the weighing area for the duration of the interview. Drivers who go to the podium are permitted to be weighed on the P21 Motorsport scale.

Any differences between the P21 Motorsport scale and the official scale are taken into account. Drivers who do not go directly to the weighing area to be weighed will be reported to the Stewards of the Meeting. The Stewards of the Meeting will take the final decision regarding a punishment.

The drivers will be weighed individually and will receive a weighing report on the determined weight. Any appeal against the observed weight must be immediately submitted to the Technical Scrutineers after receiving the report.

1.6.13 - Replacement and loss of car parts

In case of a loss of coolant, the final weight of the car may be only determined by draining all remaining coolant liquid (from engine, coolant reservoir, all radiators, all coolant hoses and connectors) and adding 25 kg to the measured weight of the car. The decision to do so is at the sole discretion of the Technical Scrutineers.

Should a car be presented for weighing with lost or damaged parts it shall be at the sole discretion of the Technical Scrutineers to determine the parts that should be replaced prior to the car being weighed.

1.6.14 - Parc Fermé rules for car weighing

Cars that have been specified for weighing are subject to Parc Fermé Regulations. It is forbidden to add or remove any substance to/from the car after it has been selected to be weighed. The same applies during the weighing process and after the end of the race. Excluded are actions of the Technical Scrutineers.

1.6.15 - Weighing in below the minimum weight

If, during the post qualifying or post-race weighing procedure, the combination of car and driver (including driver equipment) is found to be below the currently applicable minimum weight, the car and driver (including driver equipment) will immediately be weighed for a second and a third time on the same scales and in the same condition after the same session and with the same measuring method (car and driver together or separated).

The maximum value of the 3 weights recorded is regarded as the actual weight for the combination of car and driver (including driver equipment).

Falling below the minimum weight during the qualifying session will be penalised with the cancellation of the qualification times achieved by the driver concerned.

The driver is allowed, however, to take up the race from the last place on the starting grid. Falling below the minimum weight in the race will result in exclusion from the points classification for the race. It is the entrant's responsibility to ensure that the race car entered by him/her can be brought directly to the weighing area when instructed by the Stewards or the Technical Scrutineers at any time during the event. In any case, Parc Fermé rules apply to the car from the moment of the order until the termination of the weighing process.

Moreover, Parc Fermé rules apply to the route to the weighing area and in the weighing area itself. Only the responsible sporting marshals and their helpers are permitted to enter the weighing area. In this area, the only activities on the car are those expressly permitted by the aforementioned persons.

If a car is not presented for weighing despite a request, the Technical Scrutineers will inform the Stewards.

1.6.16 - Bringing the car to the weighing area

It is the competitor's responsibility to ensure that the race car entered by him can be brought directly to the weighing area when instructed by the Stewards or the Technical Scrutineers at any time during the event. In any case, Parc Fermé rules apply to the car from the moment of the order until the termination of the weighing process.

1.6.17 - Regulations on the route to and in the weighing area

Moreover, Parc Fermé rules apply to the route to the weighing area and in the weighing area itself. In addition to the Technical Scrutineers, only the responsible sporting marshals and their helpers are permitted to enter the weighing area. In this area, the only activities on the car are those expressly permitted by the aforementioned persons. If a car is not presented for weighing despite a request, the Technical Scrutineers will inform the Stewards.

1.7 - Car damage

Should a car be presented for weighing with lost or damaged parts it shall be at the sole discretion of the Technical Scrutineers to determine the parts that should be replaced prior to the car being weighed.

1.8 - Emissions regulations

The cars must be equipped with a catalytic converter as supplied by Dr. Ing. h.c. F. Porsche AG and in accordance with the RFEDA exhaust prescriptions. Only manifolds with the following parts numbers are permitted:

Left exhaust manifold:	997.113.021.A1
Right exhaust manifold:	997.113.022.A1
Exhaust silencer:	997.111.02792

1.9 - Noise regulations

The maximum permitted noise limits are 112 dB(A) measured in compliance with the FIA Annex J, Art. 252-3.6 of the ISC.

Government environmental rules may override these Noise Regulations during an Event.

The PSCI organisation is not responsible for any consequences for exceeding the noise limits imposed by the circuit or local ASN. For example, due to different measuring procedures or tolerances.

All cars must be equipped as shown in the following figure - two left and right catalysts and a central exhaust pan which must have the core -.

1.10 - Safety equipment

Unless stated otherwise, the cars must possess safety equipment as indicated by Art. 277, Category “II-SH”, current Appendix J of the FIA ISC.

The on-board fire extinguisher system must be switched into position “Armed” and the red LED illuminated from the moment a car leaves its team area to attend a free practice, qualifying or race session and must not be switched off until the car is returned to the team area or Parc Fermé after the session.

It is the Competitor responsibility to comply with this infringement shall result in a penalty which will be levied by the Stewards

1.11 - Fire extinguisher

From the moment that the race Car leaves the team’s (entrant) tent or garage to attend a Free practice, Qualifying or Race session until the end of Parc Fermé, the Car’s fire extinguisher must be active.

1.11.1 - Fire prevention

It is the team (entrant) responsibility to have min two 9kg ABC Dry Powder or alternatively two 5kg CO2 fire extinguishers present in the teams’ tent/awning/garage box at all time. The fire extinguishers must be clearly visible and easily accessible. Any non-compliance will be reported to the Stewards of the Event and penalized at the full discretion of the Stewards of the Event.

1.12 – Pit Lane safety

1.12.1 - Unless instructed otherwise by the Race Director, during all practice and qualifying sessions cars must be parked at an angle of 45 degrees, nose in towards pit garages, whenever they are stopped in the Team’s pit area. When a car is ready to leave its pit area, the car must be pushed backwards (not reversed under its own power) with a team member responsible for ensuring the car is released safely and without impeding other cars.

1.12.2 - Compressed air equipment

For all high-pressure compressors used to fill air bottles, the competitor must be able to show proof that maintenance by a relevant specialist company has been undertaken within the previous 24 months. All compressed air bottles and hoses must not be more than 10 years old at the time of use and they must show no signs of visible damage. All compressed air bottles must be protected from falling over at any time. Any attached pressure reducers, gauges or valves must be protected from releasing gas or breaking off should they fall over or be knocked or hit in any way.

1.13 - Fuel type and single fuel

1.13.1 - The following single fuel must be used:

The only permitted fuel is commercial, unleaded fuel in compliance with Art. 252.9 of the Appendix J (ISC) which must comply with DIN EN 228 must be obtained from a supplier designated by the Promoter. Only this fuel is permitted to be used for the duration of the event. The only fuel allowed during all events is described in Art. 28.3 of the PSCI Sports Regulations

1.13.2 - Fuel controls



The Technical Scrutineers shall be entitled to take fuel from a participant's car at any time during the event.

The Competitor must ensure that at any time from the start of the Pre-Grid for any session until the car is released from Parc Fermé at the end of the respective session (subject to removal of fuel for the weighing procedure), a minimum of 3 liters of fuel can be taken from the corresponding removal point (defuelling coupling of the fuel cut-off valve) in the luggage compartment.

This rule also applies to any free practice session.

These samples must be identical to the reference fuel taken from the supplier designated above.

Any infringement shall result in a penalty which will be levied by the Stewards

If the Technical Scrutineers order to defuel the car (for example to check the minimum weight of the car without residual fuel), a fuel sample can be taken prior to defueling the car.

The defuelling process will be done on the measuring platform of the Technical Scrutineering area. If necessary, the Technical Scrutineers may specify a different location. During the defuelling the vehicle must be stood on the platform (or the ground if a different location has been specified) on all four tyres and must not be moved. The required quantity of fuel must be able to be taken, from the removal point defined above, within a maximum period of 10 minutes after the start of defuelling.

1.13.3 - Refuelling, Refuelling installations and control

The addition of any additives or any chemical changes to the fuel are prohibited.

All additives are prohibited. Fuelling and refuelling of the cars during free practice, qualifying and the race is forbidden.

Throughout the race event the temperature profile of the outdoor air temperature will be recorded by the Technical Scrutineers with the use of a special temperature recorder defined by the Promoter. The minimum value of the last 24 hours will be posted on the official notice board before the first session of each day. At no time is the fuel temperature permitted to be less than the lowest outdoor air temperature as post-ed on the notice board.

Any operations involving the handling of fuel require the proper grounding to earth of the car and all equipment involved; in addition, there must be two 9kg ABC Dry Powder or alternatively two 5kg CO2 fire extinguishers present in the area of the fuel operations.

Fuel may only be added or removed into or from the fuel cell of the car using a closed-circuit fuelling system manufactured by a specialist company (the Series Organiser reserves the right to inspect any system being used and approve or disapprove its use). The exact specification of the closed-circuit fuelling system may be chosen by the Competitor according to their needs (size, pump speed, etc.) however no safety aspect of the system is permitted to be changed.

The fuel will only be supplied in drums and may only be added and removed from the drums with the same closed-circuit fuelling system specified using a suction pipe.

Should there be any circumstances where a Competitor is unable to use the closed-circuit fuelling system, then with the permission of the Technical Scrutineers, any fuel operations must be performed outside the Team tent in a fenced and gated area of at least 5m in each direction of the car. All personnel working in this area must wear full fireproof clothing (including shoes, gloves, goggles, balaclavas, etc.).

The car and all equipment must be grounded to earth properly and at least two 9kg ABC Dry Powder or alternatively two 5kg CO2 fire extinguishers with stand-by personnel (not involved in any fuel operations) must be present in this area. Under no circumstances must members of the public, Competitors, team guests or

unauthorised personnel be permitted in this area at any time during the fuelling operation; it is the responsibility of the Competitor to ensure that such persons are excluded from the area.

Any work requiring the fuel cell to be opened may only be performed after all fuel has been completely removed from inside the fuel cell and with appropriate protection and fire extinguishers being present at the respective work area.

Smoking and hot works are prohibited when any operation involving fuel or the fuel cell is in progress.

1.13.4 - Fuel circuit – Only to model 991.2

Only the fuel system permitted for the Porsche 911 GT3 Cup cars MY2017-2019 is allowed to be installed.

Additionally to the original fuel system, every car must be equipped with the after-sales defueling appliance named “option defueling-kit” and consisting of the following parts:

breakaway coupling	2x 997.110.191.8C
sealing washer	2x 991.201.883.9A
support washer	2x WHT004800
adapter piece	1x 9F0201156
drain hose	1x 9F0201627
clamp	1x 900.171.014.01

The running of the car using the service position of the fuel pumps is prohibited, unless there is a technical issue with the system.

The system may not be used with any of the pumps switched to service position for more than one lap.

2 - Specific Technical Regulation, Porsche 911 GT3 Cup, Type 991, Gen I (MY 2013–2016)

In addition to the definitions in the General Regulations, Definitions and Clarifications regarding the Technical Regulations the definitions set out in Appendix J (Art. 251 ISC of the FIA) shall apply.

2.1 - General information

Technically identical Cars with the designation Porsche 911 GT3 Cup (type 991, Gen 1), built by Porsche AG in a small production run on the basis of the Porsche 911 GT3, shall be used for the Porsche Sprint Challenge Iberica. Only Cars of model year 2016 (see following General car description) and model years 2015, 2014 as well as 2013 taking into account the required modifications (see Attachment 1) are permitted.

Certain special parts used in the Porsche 911_GT3_Cup cannot be obtained via the Porsche dealer organisation but instead can only be obtained from the Motorsport Parts Sales Department at Porsche_AG, Weissach.

The Cars must comply with the requirements of these Technical Regulations.

Technical acceptance of the Cars is undertaken by the technical scrutineers.

2.2 - General car description

Porsche 911 GT3 Cup (type 991 Gen 1), MY 2013-2016

2.2.1 - Concept

- Single-seater production-based race car
- Basis: 911 GT3

2.3 - Engine

- Aluminium rear-mounted flat-six engine
- 3.800 cm³; stroke 76.4 mm; bore 102.7 mm
- Max. power: 338 kW (460 hp) at 7,500 rpm
- Max. engine speed: 8,500 rpm
- Single-mass flywheel
- Water cooling with thermal management for engine and gearbox
- Four valves per cylinder
- Sequential multi-point fuel injection
- Fuel octane rating: minimum 98 octane ROZ premium unleaded
- Dry-sump lubrication
- Electronic engine management (Bosch MS 4.6)
- Race exhaust system with regulated race catalytic converter
- Rear silencer with twin tailpipe in central arrangement
- Electronic accelerator pedal

Alternatively to the original part the following flywheel code is authorized: 997.102.041.93

The original screws for fixation of the exhaust system may be replaced by steel bolts and hexagon nuts.

Therefore it is only allowed to use the following parts:

4 pieces of steel stud M10x70 8.8. part number: 999.062.170.02

4 pieces of hexagon nuts M10, part number: 900.377.011.01

The implementation of this modification has to comply with the photo below.



2.3.1 - Engine Electronic Control Units

Throughout the entire event, only the Bosch Motronic electronic control units coded and sealed by the Promoter are allowed to be used.

The Motronic electronic control unit incl. the complete wiring harness must be used without modifications. The PCCI Technical Manager or the Technical Scrutineers reserve(s) the right to check or exchange the Motronic electronic control unit or record the engine characteristic data at any time during the event. The Promoter reserves the right to reprogram the Motronic electronic control units and to seal the plug-in connectors for reading the electronic control units at any time. It is thus ensured that the status of the program and data are identical for all participating cars.

2.3.2 - Exhaust System

Only the Porsche original Race exhaust system, that includes the central rear muffler, is permitted to be used. The exhaust system without mufflers is prohibited.

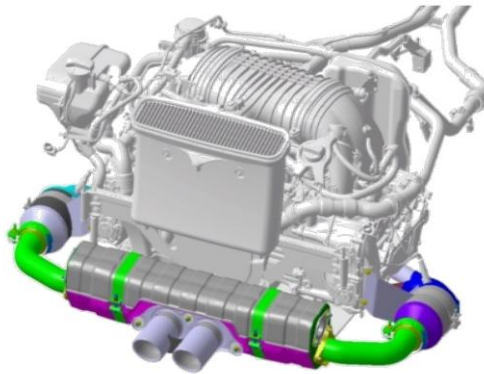

For references of exhaust system parts see Attachment 13

2.3 - Power Transmission (gearbox/differential lock)

a) General Description

- Porsche six-speed sequential dog-type gearbox
- Gear ratios:
 - Ring & pinion gear 14/22 $i = 1.571$
 - Final drive 17/41 $i = 2.412$
 - 1st gear 13/41 $i = 3.154$
 - 2nd gear 17/40 $i = 2.353$
 - 3rd gear 19/36 $i = 1.895$
 - 4th gear 19/29 $i = 1.526$
 - 5th gear 24/30 $i = 1.250$
 - 6th gear 34/35 $i = 1.029$
- Internal pressure-oil lubrication with active oil cooling by oil-water heat exchanger
- Mechanical limited slip differential
- Triple-disc sintered metal race clutch
- Pneumatic gear shift activation (paddle shift)

2.4 - Body

- Lightweight bodywork with smart aluminium-steel composite construction
- Welded-in roll cage certified in compliance with FIA homologation regulations for safety cages
- Front bonnet with 2 air inlets for cockpit ventilation and quick fasteners
- Removable rescue hatch in the roof
- Holder for recovery beam system same as DTM system
- Modified 911 GT3 wings with flared wheel arches
- Widened rear wheel arches
- Modified and widened 911 GT3 front apron with spoiler lip
- Modified GT3 rear apron with integrated rain light in compliance with FIA Regulations
- Lightweight exterior equipment:
 - CRP doors with Sport-Design rear-view mirrors
 - CRP rear lid with quick-action fasteners
 - CRP rear wing, adjustable
 - PC rear side windows with ventilation openings
 - PC rear window
- Underbody panelling with air routing for brake and driveshaft cooling on the rear
- Modified 911 cockpit:
 - Weight-optimised magnesium subframe
 - Ergonomic driver-oriented centre console
 - Trim for switches with fluorescent lettering
 - Steering wheel with quick-release coupling, control panel and shift paddles
- Racing bucket seat with fore/aft adjustment:
 - Homologation according to the latest FIA requirements
 - Individual padding system
- 6-point seat belt
- 100-litre FT3 safety fuel tank
- 3-point air jack system

2.5 - Chassis

2.5.1 - Front axle:

- McPherson suspension strut, adjustable in height, wheel camber and track
- Forged struts:
 - Optimised stiffness
 - Two-shear connection
 - Heavy-duty spherical bearings
- Wheel hubs with central locking
- Racing shock absorbers, non-adjustable
- Forged supporting mounts

- Double-blade-type anti-roll bar
- Power steering with electrohydraulic pressure feed

2.5.2 - Rear axle:

- Multi-link rear axle, adjustable in height, wheel camber and track
- Forged struts:
 - Optimised stiffness
 - Two-shear connection
 - Heavy-duty spherical bearings
 - Wheel hubs with central locking
 - Racing shock absorbers, non-adjustable
 - Forged supporting mounts
 - Double-blade-type anti-roll bar

2.5.3 - Ramp Breakover Angle

The ramp breakover angle of the differential lock is 52° (traction) and 30° (overrun). The ramp angles are determined from the axis of rotation (Attachment 6). The number of friction plates and the assembly order shall correspond to the image shown and must not be changed. The fitted friction plates must comply in terms of part number, allocation and specification (see parts catalogue).

2.5.4 - Transmission Emergency Function

After the transmission emergency function has been switched on by the Driver, the car must immediately return to the pit lane.

The car is not allowed to leave the pit lane again until this function has been deactivated.

2.6 - Brakes

Only cars with the brake calipers are permitted that correspond with the delivery conditions.

2.6.1 - General Description

2 independent brake circuits for front and rear axles, adjustable by the driver via brake balance system

2.6.2 - Front axle:

- Aluminium 6-piston racing callipers, one piece, parts number:
 - FL: 991.351.427.8A
 - FR: 991.351.428.8A
- Internally vented brake discs, diameter = 380 mm, 32 mm thick, parts number:
 - FL: 991.351.105.8A
 - FR: 991.351.106.8A
- Racing brake pads, parts number:
 - 991.351.942.8A (sprint version)
- Optimised brake-air ducting

2.6.3 - Rear axle:

- Aluminium 4-piston fixed calipers, one piece, parts number:

FL: 991.352.427.8A

FR: 991.352.428.8A

- Internally vented brake discs, diameter = 380 mm, 30 mm thick, parts number:

FL: 991.352.107.8A

FR: 991.352.108.8A

- Racing brake pads, parts number:

991.352.942.8A (sprint version)

A knock-back spring must be installed in each case under each brake piston of all brake calipers. External thermal or chemical treatment of these springs is prohibited. Only the following parts are permitted to be used:

Front axle: 991.351.963.8A

Rear axle: 991.352.963.8A

2.6.4 – ABS System

The use of ABS system or traction control is allowed. In case an ABS system is mounted, the use of the master brake cylinder with Porsche part nr 991.355.170.8E is mandatory. It is allowed to equip the brake caliper lines with quick connectors.

✘ All 991 GT3 Cup model year 2016 Cars MUST be modified before further use. The master Cylinder pushrod must be changed by the pushrod with part number 9914239498A

2.7 - Wheels (flange + rim) and tyres

Only the version of Michelin tyres approved for the Series races with the following specification is allowed to be used for the duration of the events and the official tests.

2.7.1 - Slick tyres

Front axle:

– Single-piece light-alloy rims according to Porsche specifications and design, 10.5 J x 18 RO 28, with central locking

– Michelin transport tyres; tyre size: 27/65 R 18

Rear axle:

– Single-piece light-alloy rims according to Porsche specifications and design, 12 J x 18 RO 53, with central locking

– Michelin transport tyres; tyre size: 31/71 R 18

2.7.2 - Rain tyres

FA: 27/65 R 18 P2L

RA: 31/71 R 18 P2L

Michelin's recommendations and instructions relating to tyre pressure and set-up must be observed. Only atmospheric air is allowed to be used to inflate the tyres. It is not permissible to refit or rotate the tyres on the rims.

Wet tyres are allowed to be used to drive to and from the pit lane for the free practice and qualification sessions.

2.8 - Steering (steering wheel/hub extension)

The position of the steering wheel on the front axle control arm is determined by spacer washers with a thickness of 8.5 mm (part number: 991.341.613.8A). No hub extensions are allowed to be installed. The standard longitudinal and height adjustment facility is allowed to be used.

Line 991.347.775.8A of the steering gear must be provided with a vibration damper 8K0.611.797.E in the arrangement as shown.

2.9 - Wheel suspension

2.9.1 – General description front axle

McPherson suspension strut, adjustable in height, wheel camber and track

- Forged struts
- Optimised stiffness
- Two-shear connection
- Heavy-duty spherical bearings
- Wheel hubs with central locking
- Racing shock absorbers, non-adjustable
- Forged supporting mounts
- Double-blade-type anti-roll bar
- Power steering with electrohydraulic pressure feed

2.9.2 – General description rear axle

Multi-link rear axle, adjustable in height, wheel camber and track

- Forged struts
- Optimised stiffness
- Two-shear connection
- Heavy-duty spherical bearings
- Wheel hubs with central locking
- Racing shock absorbers, non-adjustable
- Forged supporting mounts
- Double-blade-type anti-roll bar

2.9.3 – Wheel suspension

The suspension is allowed to be modified within the scope of the specified setting range. All genuine parts must be retained. The max. permissible thicknesses of the spacer washers in the front and rear axle control arms are:

- Front axle: 18 mm
- Rear axle: 15 mm

Furthermore, it is optional to fix the camber shims with aluminium tape.

The trailing arm axle bearing points of the front and rear control arms must be left in the position in which they are delivered.

Additionally, the screw positions of the trailing arms at the wishbone bearing points may not be modified (see Attachment 8).

The wheelbase on the left and right sides of the car must be 2,460 mm +/-15 mm.

The measuring points are the centres of the wheel hubs.

2.10 – Anti-roll bars

The anti-roll bars are only allowed to be unhooked provided that no parts are removed in the process. Only the setting options for which the technical specifications have been provided are allowed to be used. Shims are allowed to be used to compensate for the axial clearance of the anti-roll bars on the front and rear axles. These are available in the following versions:

1 mm with the spare part number 991.343.761.8A

2 mm with the spare part number 991.343.761.8B

Other shims or methods for axial clearance compensation must not be used.

However, the overall axial clearance must not be less than 2 mm referred to each anti-roll bar.

2.11 – Tie rods

The replacement of the inner Torx screw with part number 999.073.252.09 by an external hex screw with part number 900.378.103.01 is not subject to any restrictions.

2.12 – Shock absorbers/springs

Only the factory-installed Sachs shock absorbers and H&R chassis springs in their original condition are allowed to be used. The following number is stamped on the bump stops of the rear vibration dampers: 0049 5111 0 250. The original delivery condition of the bump stops of the front and rear dampers must not be modified in any way.

Part numbers:

Vibration Damper:	Front: 991.343.045.8D	Rear: 991.333.051.8A
Bump stop:	Front: 991.343.677.8A	Rear: 991.333.677.8A
Main spring:	Front (240 N/mm): 991.343.531.8C	Rear (260 N/mm): 991.333.531.8C
Helper spring:	Front (75/60/45): 996.343.537.90	Rear (80/60/60): 997.333.537.90

2.13 – Bodywork

2.13.1 – General description

- Lightweight bodywork with smart aluminium-steel composite construction
 - Welded-in roll cage certified in compliance with FIA homologation regulations for safety cages
 - Front bonnet with 2 air inlets for cockpit ventilation and quick fasteners
 - Removable rescue hatch in the roof
 - Holder for recovery beam system same as DTM system
 - Modified 911 GT3 wings with flared wheel arches
 - Widened rear wheel arches
 - Modified and widened 911 GT3 front apron with spoiler lip
 - Modified GT3 rear apron with integrated rain light in compliance with FIA Regulations

2.13.2 – Bodyshell protection

It is highly recommended to have the Car equipped with the protection plates for the rear cast aluminium sub frame (PPN: 9915803168A, 9915803158A, 9915803188A, 9915803178A)

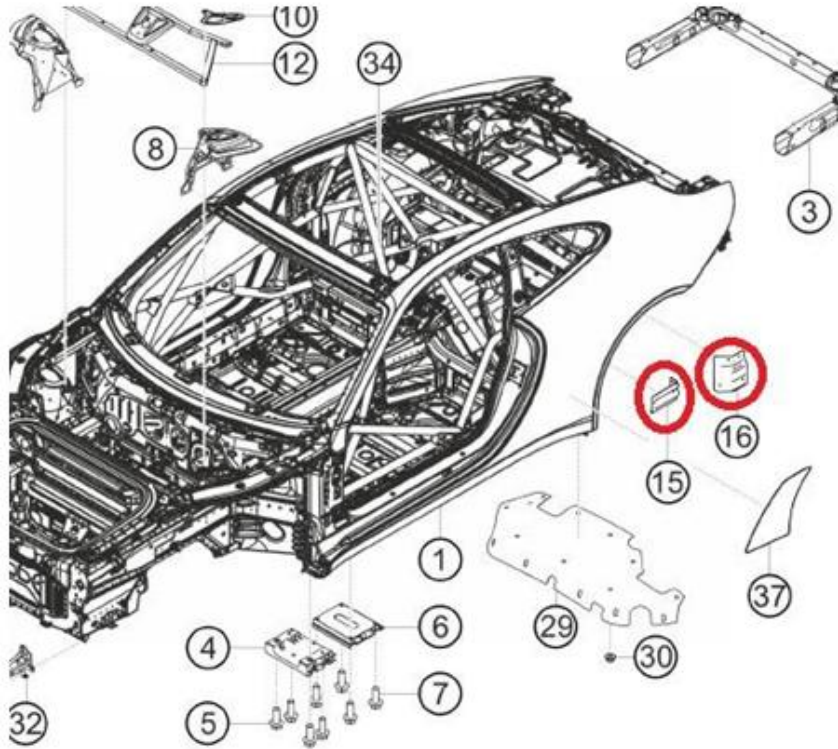

2.14 – Lightweight exterior equipment

- CRP doors with Sport-Design rear-view mirrors
- CRP rear lid with quick-action fasteners
- CRP rear wing, adjustable
- PC rear side windows with ventilation openings
- PC rear window
- Underbody panelling with air routing for brake and driveshaft cooling on the rear
- Modified 911 cockpit:

Door retaining bolts which are mounted in the door hinges can be changed by a non-Porsche genuine bolts. This should be a threaded bush bolt with a female 4mm Allen head M8x1x16. You can purchase this item from the Porsche Sprint Challenge Iberica Support team.



2.15 – Modified 911 cockpit

- Weight-optimised magnesium subframe

- Ergonomic driver-oriented centre console
- Trim for switches with fluorescent lettering
- Steering wheel with quick-release coupling, control panel and shift paddles
- Racing bucket seat with fore/aft adjustment:
- Homologation according to the latest FIA requirements
- Individual padding system
- 6-point seat belt
- 100-litre FT3 safety fuel tank
- 3-point air jack system

2.15.1 – Overall car length and overhangs:

- The overall length of the car is 4,547 mm +/-10 mm.
- The Overall width: 1,851 mm
- The Overall height: 1,280 mm
- The Wheelbase: 2,460 mm

The front overhang is 1,043 mm +/-10 mm, measured from the middle of the wheel of the front axle to the leading edge of the car (first point in the direction of the longitudinal axis, incl. front lip).

The rear overhang is 1,045 mm +/-10 mm, measured from the middle of the wheel of the rear axle to the rear edge of the car (last point in the direction of the longitudinal axis, rear wing excluded).

2.15.2 – External bodywork (including windows)

The delivery status of the bodywork has to be preserved.

2.15.3 – Windscreen

In addition to the original part, windscreens of the 911 GT3 Cup MY 2013-2017 with the part number 991.541.911.00 are allowed to be used, as well as windscreens of the Porsche 911 GT3 street Car with part number 9P1845011C.

Heated windscreens with part number 991.541.111.8B are permitted.

The windscreen is allowed to be connected to the electrical system of the car and the function is allowed to be used.

To protect the windscreen and as a safety measure, so-called tear-off screens are allowed to be attached to the windscreen. Fitting will be checked by technical scrutineering and must be removed where applicable on request of the Technical Scrutineers.

2.15.4 – Side and rear windows

Only the genuine Porsche 911 GT3 Cup side and rear windows (in accordance with ISC of the FIA, Appendix J) in their original version are permissible.

Door window

Left:	991.542.511.8B	as well as	991.543.511.8C	991.543.511.8F
Right	991.542.512.8B	as well as	991.543.512.8C	991.543.512.8F

Rear side window

Left: 991.543.511.8A

Right: 991.543.512.8A

Rear window

991.545.111.8A

Additionally, the rear window must be fixed with the rear window repair kit (part number: 991.545.901.8A).

2.16 – Cockpit

2.16.1 – Seat

The adaption of the seat by removing or adding of original Recaro seat padding is forbidden in the areas of the seat shown in green colour on the illustration of attachment 13. Any modification of the seat padding shown in green colour is strictly prohibited. The use of the different sizes paddings is allowed, also in the areas shown in green colour, as long as they are not modified. An upholstery in the bottom part of the seat on top of the paddings shown in green (see illustration in attachment 13), as long as the original padding is not modified or removed.

An upholstery of the areas shown in yellow colour on the illustration of attachment 12 is allowed by either using original Recaro paddings or using a foamed seat insert, as long as the insert is made of fireproof material, colored in black and its maximum thickness at any point does not exceed 50 mm in size. The use or change is subject to approval by the series organisation.

The preferred supplier for padding components is the seat manufacturer (Recaro). The original seat mounting (seat rails and bracket) must be retained and must not be modified.

2.16.2 – Ventilation in the passenger compartment

Only the factory-fitted ventilation pipe (NACA-intake on the front opening hood) is permissible for cockpit ventilation. The ventilation of the windscreen must not be affected.

For additional ventilation of the passenger compartment only the existing original ventilation openings in the rear back windows are permissible.

The dimension of the NACA-intake port on the driver's side is allowed to be changed by taping.

2.16.3 – Additional roof hatch accessories

The car has an opening in the roof in order to make using the KED system easier should it become necessary to rescue the driver. The roof hatch is located directly above the driver and with the dimension of the opening 420 x 420 mm.

The roof hatch is connected to the roof via 4 livelocks.

2.17 – Ground clearance of car

The minimum ground clearance of the ready-to-drive car (with the driver in the car and slick tyres in compliance with Article 2.7, at 2.0 bar \pm 0.1 bar air pressure) must not be less than the specified dimension, as measured at the specified measuring points, at any time during the race event.

For the entire duration of the race event the ground clearance of the front axle is to be a minimum of 78 mm and the clearance at the rear axle a minimum of 100 mm. The measuring points (see Attachment 9) at the front axle are the mounting bolts (M12x105) of the cross member/bodywork in relation to the reference surface and the machined rear surface in the direction of travel on the side section of the rear axle in relation to the reference surface. The ground clearance is allowed to be changed within the existing adjustment range.

Applicable to MY 2013 Cars: For the purpose of setting the measuring point on the front axle, the washer with part number 991.341.641.8A of exactly 10 mm thick must be removed at the measuring points (in accordance with Attachment 9). The previously used bolts for securing the front axle carrier (height measuring point) must be replaced with bolts with the part number 999.072.864.01 (M12x105). This results in the minimum ground clearance at the front axle of 78 mm.

The front underbody must be cut out in the area of the height measuring points in accordance with the picture in Attachment 10.

2.17.1 – Measuring method

The minimum ground clearance of the ready-to-drive car is checked using a measuring plate and appropriate height gauges for the axle to be measured in each case. The measurement is checked with the ready-to-drive car incl. the driver on board, standing on the measuring plate. If the measuring gauges can be accessed under the measuring points described above, the requirement to comply with the minimum height is satisfied. Any measuring tolerances will be taken into account by the technical scrutineers. Verification of the car ride height can also be done with Porsche AG measuring wheels. The Technical Scrutineers can also use instruments like a callipers or a depth gauge to determine the car height instead of a gauge.

a) Measurement location

The measurement is conducted on the measuring plate during technical scrutineering. The measuring plate is available to the participating teams to check the minimum ground clearance during this period after consultation with the Technical Scrutineers. A check can also be made in the pit lane for the duration of the qualifying session.

Failure to reach minimum height

Failure to reach the minimum height during the qualifying session will be penalised with the cancellation of the times achieved by the driver concerned.

The driver is allowed, however, to take up the race from the last place on the starting grid. Failure to reach the minimum height in the race will result in exclusion from the points classification for the race.

2.18 – Mounting for front silencers

Changes to the body to secure the front silencers (cutting insulation and rivet bolt) are permitted under Attachment 11.

2.18.1 – Colour

- Water-based paint
- Exterior: White (C9A)
- Interior: White filler-coat, no clear-coat finish

2.19 - Aerodynamic devices

The original position of the wing section is allowed to be changed within the specified scope for adjustment.

Masking the central cooler in horizontal line to regulate the water temperature of the engine is allowed. Masking of the side radiators for additional control of the coolant temperature is only permitted if the centre radiator has already been completely masked. The masking must comply with the Sticker Regulations.

One strip of transparent adhesive tape (max. 80 mm long, 20 mm wide) is permitted as a fixing element on the headlights, the tail lights, the front wheel covers (9915053668AG2X and 9915053658AG2X), at a 90° angle in relation to the particular gaps that are taped over. Complete masking of the filler flap on the wing is also approved.

Furthermore, the teams are allowed to tape over the full area of the headlight lenses with transparent Heli tape, without thereby taping over a slot in the bodywork.

Apart from that, taping over of slots in the bodywork and openings is not allowed.

2.20 - Electrical equipment

From the pre-start to the end of the Parc Fermé during qualifying and racing, only the Series organiser and personnel nominated by the Series organiser are allowed to connect laptops/computers to the Cars. Any breach of this regulation may result in the car being excluded from qualifying or racing.

2.20.1 – General description

- COSWORTH ICD colour display
- COSWORTH electrical system control unit IPS32
- Electronic accelerator pedal
- Fire extinguishing system (extinguishing agent: gas)
- 12 V, 70 Ah (AGM) battery, leakproof, placed in passenger's footwell
- 150 A alternator
- Weight optimised fan
- Wiper with direct drive

2.20.2 - Lighting system

- Bi-Xenon headlights
- LED daytime driving lights
- LED rear lighting system and rain light (See Attachment 12)

Permitted options

- Brake pressure and steering-angle sensors
- COSWORTH ICD memory extension 128 MB
- Bosch MSA box
- Oil level display (997.641.139.9A and cable loom 991.612.334.8A)

2.21 - Fuel circuit

Only the fuel system permitted for the Porsche 911 GT3 Cup Cars of model years 2016 and 2015 is allowed to be installed.

In addition, the in-tank wiring harness of model year 2013 with part numbers 991.201.697.8A or alternatively 991.201.697.8J is allowed to be used.

2.22 - Lubrication system

2.22.1 - Lubricants

a) Engine:

Mobil 1 OW-40 engine oil is compulsory. All additives are prohibited.

b) Transmission:

Mobilube 1 SHC 75W-90 transmission oil is compulsory. All additives are prohibited. There has to be a minimum of 2.7 litres of transmission oil in the gearbox at all times during the event.

2.23 - Miscellaneous

2.23.1 - Chassis

There are no specifications regarding the choice of chassis springs and shock absorbers. A spacer ring is allowed to be installed between the bodywork and the support bearing.

2.24 - Brakes

As set out in Appendix J of the FIA documentation, there are no specific regulations regarding brake pads and brake callipers.

2.25 - Transmission

There are no specifications regarding transmission ratios.

2.26 - Clutch

There are no specifications regarding the use of a clutch system approved by Porsche AG.

2.27 - Fuel tank

There are no specifications regarding the use of a safety tank approved by Porsche AG and a suitably approved tank in accordance with FIA documentation, Appendix J, Art. 257.6.

2.28 - Noise regulations

The noise limits of the relevant Event Regulations must be observed.

2.29 - Lighting

There are no specifications regarding lighting in accordance with FIA documentation, Appendix J, Art. 257.8.

2.30 – Safety Nets



It is mandatory to equip the Cup Car with the after sales safety net mounted on the left side of the Driver. As specified in the valid spare parts catalogue and mounted complying with the Porsche AG mounting instructions.

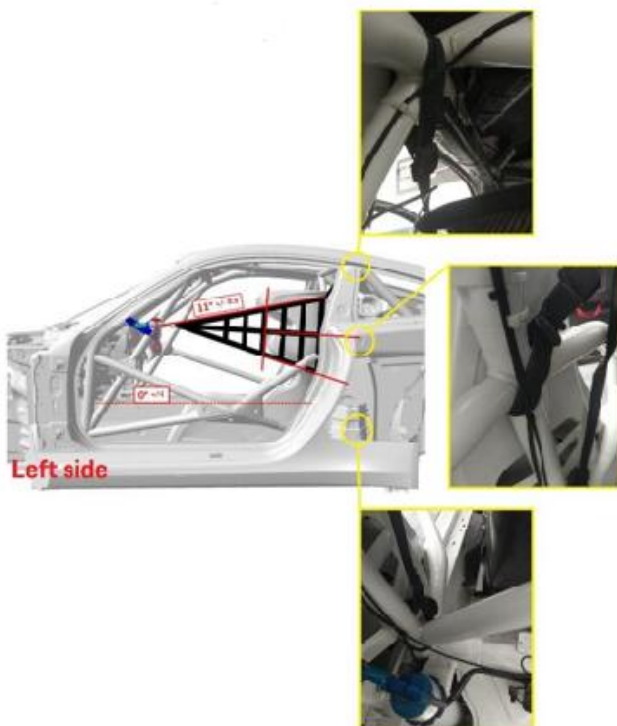

2.31 – Roll cage safety padding



All Porsche GT3 Cup, type 991 Gen I Cars, must be equipped with the mandatory rollcage padding.

Y-rollcage:

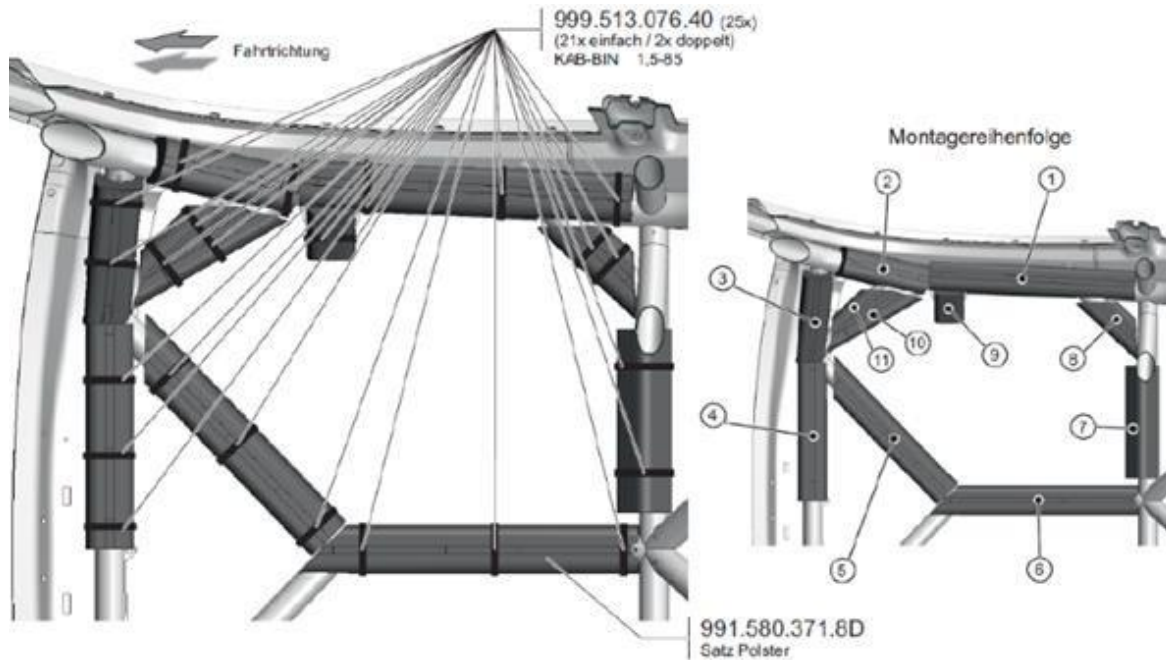

Diagonal-rollcage:

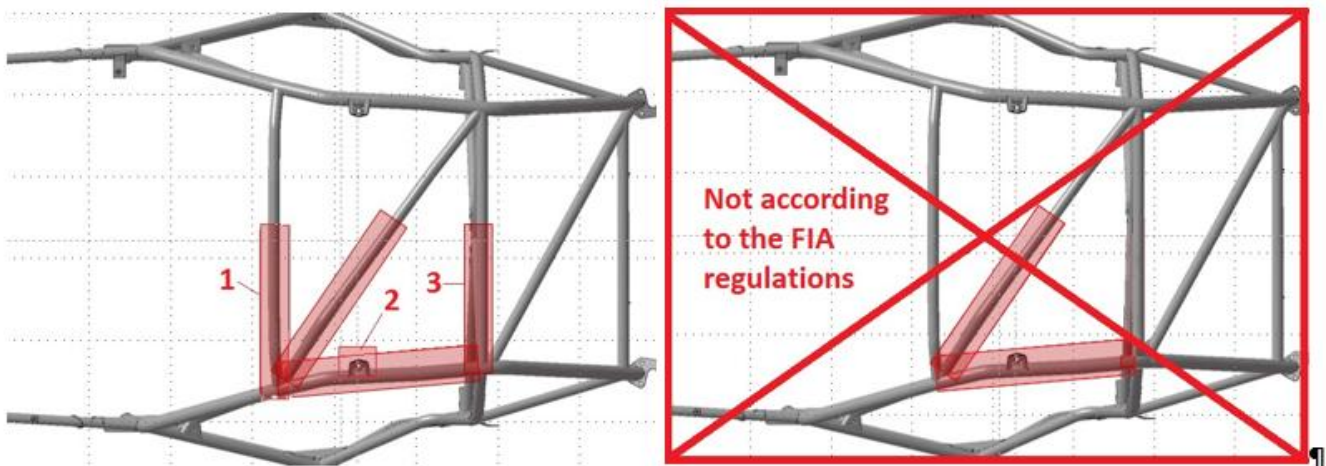

All Porsche GT3 Cup, type 991 Cars, must be equipped with the mandatory rollcage padding located in the Drivers footwell.

(PPN.: 9F0.880.413)

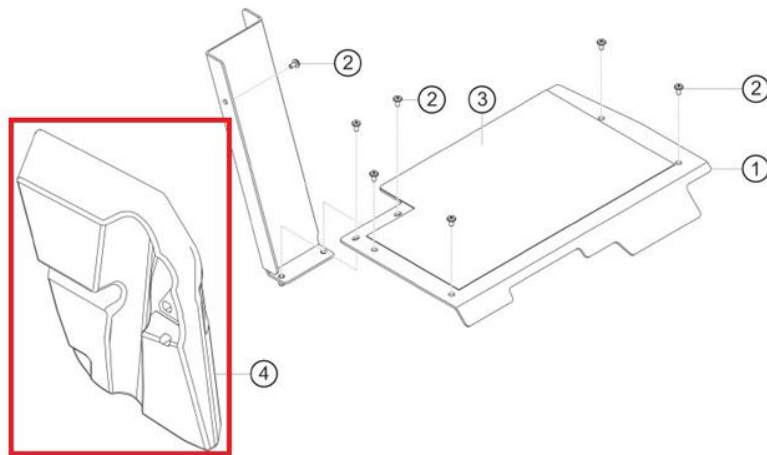

2.32 – Filter cable

- ✘ All Porsche GT3 Cup, type 991.1. Cars must be equipped with the mandatory Filter cable. PPN.:9916127638B

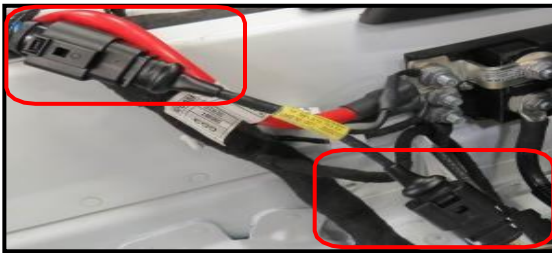

2.33 – Fuel circuit

Only the fuel system permitted for the Porsche 911 GT3 Cup Cars of model years 2016, 2015 and 2014 is allowed to be installed. In addition, the in-tank wiring harness of model year 2013 with part numbers 991.201.697.8A or alternatively 991.201.697.8J is allowed to be used. Additionally, to the original fuel system, every Car can be equipped with the after sales defueling appliance consisting of the following parts:

- breakaway coupling: 2x 9971101918C
- sealing washer: 2x 9912018839A
- support washer: 2x WHT004800
- adapter piece: 1x 9F0201156
- drain hose: 1x 9F0201627
- clamp: 1x 90017101401

The running of the Car using the service position of the fuel pumps is prohibited, as long as there is no technical issue with the system. The system may not be used with any of the pumps switched to service position for more than one lap.

22 – Optional parts

All parts found in the parts catalogue, from the eligible Car, as indicated as an option are allowed to be used. Including endurance parts that aren't permitted in a regular Porsche One-Make-Serie.

2.34 – Attachment 1

Technical modifications of 911 GT3 Cup (type 991.1), MY 2013 and MY 2014 for use in the Porsche Sprint Challenge Iberica

Prescribed technical modifications on Cars of model year and status 2013

1 - Automatic fuel shut-off valve

The fuel system must be supplemented by the automatic fuel shut-off valve (991.201.321.8A) and the adapter (991.201.581.8A) necessary for installation as well as the front fuel line (991.201.295.8D).

2 - Transmission support

The transmission support must be replaced by the current version MY 2014 with the following part scope:

- 1 x 991.375.137.9B Transmission holder
- 2 x 999.507.075.40 Clip 4.0–12.0
- 2 x 900.378.332.01 Hexalobular bolt M8X16
- 4 x 900.377.011.01 Hexagon nut M10
- 1 x 991.375.114.03 Longitudinal reinforcement
- 1 x 900.385.164.01 Hexalobular bolt M12X1.5X140
- 1 x 999.086.009.02 Hexalobular nut M12X1.5
- 1 x 999.072.083.01 Hexagon bolt M10X58

3 - Tie rod

The tie rod must be replaced on both sides by the current, longer version (991.341.031.8C).

4 - Rear-axle cross member

The rear-axle cross member must be replaced by the latest cast aluminium version (991.331.261.8C).

5 - Front and rear brake pads

The brake pads must be replaced by the new pads of the type "Sprint" both at the front (991.351.942.8A) and at the rear (991.352.942.8A).

6 - Mirrors

The exterior mirrors of the car must be equipped on both sides corresponding to the current, aerodynamically adapted version.

- 1 x 991.731.020.8A.C9A Z mirror, right
- 1 x 991.731.019.8A.C9A Z mirror, left
- 1 x 991.731.048.03 Mirror glass, right
- 1 x 991.731.045.02 Mirror glass, left

7 - Ignition system

The previously used spark plugs (999.170.208.90) must be replaced by spark plugs with the number 991.602.201.8A.

8 - Rain light - See Attachment 12

9 - 150 A alternator

The previous alternator must be replaced by the 150 A alternator with the items listed below:

- 1 x 997.603.019.8A Z three-phase generator
- 1 x 997.603.531.8A Generator holder
- 1 x 900.385.042.01 Hexolobular bolt M8X35 10.9
- 1 x 900.385.001.01 Hexolobular bolt M8X20 8.8
- 1 x 900.385.274.01 Hexolobular bolt M10X25 10.9
- 1 x 999.513.075.40 Tie-wrap
- 1 x 900.385.148.01 Hexolobular bolt M10X55 10.9
- 1 x 900.377.011.01 Hexagon nut M10

10 - “Megaline” gearshift system

The gearshift system and all components (compressor, valve block, shift cylinder) must be converted from “Shiftec” to “Megaline”, see the following range of parts:

- 1 x 991.618.355.8A Z compressor gearshift
- 1 x 991.605.310.8E Slave cylinder on transmission
- 1 x 991.618.485.8E Z air line valve block + compressor
- 1 x 991.618.785.8E Air line
- 1 x 991.618.471.8B Valve block
- 1 x 991.618.795.8B / 8C Valve block support
- 4 x 999.703.193.01 Damper element 15x15/M5
- 4 x 900.817.005.02 Hexagon nut M5
- 4 x 999.073.268.09 Fillister head bolt M5X12
- 1 x 991.618.765.8A Valve block adapter cable
- 4 x 996.355.857.9A Sleeve
- 4 x 999.073.270.A2 Fillister head bolt M5X20

11 - Steering gear control line

The control line of the steering gear (991.347.775.8A) must be attached with the following holder as described in bulletin 04/2014 PMSC:

- 1 x 8K0.611.797.E Holder, 3-track
- 2 x N 0209044 Tie-wrap

12 - Fuel tank

The fuel tank has been optimised (protection against static discharge, catch tank with flap valve, an in-tank pump) and must have the following parts retrofitted:

- 1 x 991.201.201.8A Z holder delivery unit
- 1 x 991.201.697.8J Fuel tank wiring harness
- 1 x 991.201.343.8A Z fuel pump
- 1 x 991.201.637.8A Fuel pump filter
- 1 x 991.201.197.8J Set of foam parts for fuel tank



PORSCHE
SPRINT CHALLENGE
IBERICA



- 1 x 991.201.735.8B Rollover valve
- 1 x 900.123.101.30 Sealing ring A 12x18
- 1 x 991.201.043.8H Z fuel filler neck

13 - Front axle damper

The front axle damper has been improved and must be replaced by the following items:

- 2 x 991.343.045.8D Front axle vibration damper
- 2 x 991.343.511.8B Spring plate
- 2 x 999.084.128.01 Hexagon nut M14

14 - Manifolds with catalytic converter

The exhaust manifolds have been optimised and must be replaced by the following parts:

- 1 x 997.113.021.A1 Manifold with catalytic converter, left
- 1 x 997.113.022.A1 Manifold with catalytic converter, right
- 1 x 997.111.02792 Exhaust silencer

15 - Rear axle wheel suspension

The rebound travel of the rear axle must be increased. For this purpose, the spacer ring on the rear suspension strut with part number 991.333.468.8A must be replaced by the thicker spacer ring with the following part number.

- 2 x 991.333.468.8B Suspension strut spacer ring

16 - Differential friction pack

The differential friction pack must be replaced by the following parts:

- 6 x 991.332.981.8B Clutch plate 1.4 mm internally toothed

In total 6 of the following pressure plates with different thicknesses (externally toothed):

- 991.332.983.8C Pressure plate 1.5 mm
- 991.332.983.8D Pressure plate 1.55 mm
- 991.332.983.8A Pressure plate 1.6 mm
- 991.332.983.8E Pressure plate 1.65 mm
- 991.332.983.8F Pressure plate 1.7 mm
- 991.332.983.8H Pressure plate 1.75 mm
- 991.332.983.8J Pressure plate 1.8 mm
- 991.332.983.8B Pressure plate 1.85 mm
- 991.332.983.8K Pressure plate 1.9 mm
- 991.332.983.8M Pressure plate 1.95 mm

3 - Specific Technical Regulations, Porsche 911 GT3 Cup, Type 991 Gen II (MY 2017-2019)

A - Technical definitions

In addition to the definitions in the "General Regulations, Definitions and Clarifications regarding the Technical Regulations" the definitions set out in Appendix J (Art. 251 ISC of the FIA) shall apply.

3.1 - General information

Technically identical cars with the designation Porsche 911 GT3 Cup (type 991 Gen II), built by Porsche AG in a small production run based on the Porsche 911 GT3, shall be used for PSCI. Only cars of model year 2017, 2018 and 2019 (see following general car description) are permitted.

General car description Porsche 911 GT3 Cup (type 991 II), MY 2017, 2018 and 2019

Concept: Single-seated, near-standard race car based on the Porsche 911 GT3. For further general descriptions, the entrant shall refer to the respective paragraph of these technical regulations.

Important Information Certain special parts used in the Porsche 911 GT3 Cup cannot be obtained via the Porsche dealer organisation but instead can only be obtained from the Motorsport Parts Sales Department at Porsche AG, Weissach.

3.2 - Engine

3.2.1 - General description

Aluminium six-cylinder rear-mounted boxer engine

3.996 cm³; stroke 81.5 mm; bore 102 mm

Max. power: 357 kW (485 hp) at 7250 – 8000 rpm

Max. rpm: 8,500 rpm

Single-mass flywheel

Water cooling with heat management for engine and gearbox

Four valves per cylinder

Variable cam phasing (Intake & Exhaust)

Direct fuel injection

Required fuel quality: minimum 98 octane, unleaded

Dry-sump lubrication

Electronic engine management (Bosch MS 4.6 NG)

Race exhaust system with regulated race catalytic converter

Rear silencer with centred exhaust pipes

Electronic throttle pedal

3.2.2 - Engine electronic control units

Throughout the entire event, only the Bosch Motronic electronic control units coded and sealed by the Promoter are permitted to be used

The engine electronic control unit including the complete wiring harness must be used without modifications. The PSCI Technical Manager or the Technical Scrutineers reserve(s) the right to check or exchange the engine electronic control unit or record the engine characteristic data at any time during the event.

The Promoter reserves the right to reprogram the engine electronic control units and to seal the plug-in connectors for reading the electronic control units at any time. It is thus ensured that the status of the program and data are identical for all participating cars.

3.2.3 - Exhaust system

Only the Porsche original Race “exhaust system”, that includes the central rear muffler, is permitted to be used. The exhaust system without mufflers is prohibited.

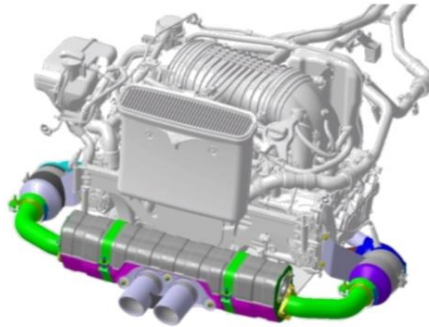

For references of exhaust system parts see Attachment 2

3.3 - Power transmission (gearbox/differential lock)

3.3.1 - General description

Porsche six-speed sequential dog-type gearbox

Sealed (for warranty purposes only)

Gear ratios:

Ring & pinion gear	14/22	$i = 1.571$
Final drive	17/41	$i = 2.412$
1st gear	13/41	$i = 3.154$
2nd gear	17/40	$i = 2.353$
3rd gear	19/36	$i = 1.895$
4th gear	19/29	$i = 1.526$
5th gear	24/30	$i = 1.250$
6th gear	34/35	$i = 1.029$

Internal pressure-oil lubrication with active oil cooling by oil-water heat exchanger

Mechanical limited slip differential

Triple-disc sintered metal race clutch

Pneumatic gear shift activation (paddle shift)

3.3.2 - Ramp breakover angle

The ramp breakover angle of the differential lock is 52° (traction) and 30° (overrun). The ramp angles are determined from the axis of rotation (Attachment 3).

The number of friction plates and the assembly order shall correspond to the image shown in Attachment 3 and must not be changed. The fitted friction plates must comply in terms of part number, allocation and specification (see parts catalogue).

3.3.3 - Transmission emergency function

If the transmission emergency function has been switched on, the car must immediately return to the pit lane. The car is not permitted to leave the pit lane again until this function has been deactivated.

3.4 - Lubrication system

Lubricants

No less than the minimum quantity of lubricants in the engine and gearbox as specified in the Technical Manual must be used at all times during any event.

The addition of any additives or any chemical changes to the lubricants are prohibited.

Engine:

Mobil 1 ESP X3 0W-40 engine oil is compulsory.

Transmission:

Mobilube 1 SHC 75W-90 transmission oil is compulsory.

3.5 - Brakes

Only cars with brake calipers that correspond with the delivery conditions are permitted. It is not permitted to modify the car to endurance brake calipers, even if they might be listed in the parts catalogue.

3.5.1 - General description

Two independent brake circuits with brake pressure sensors for front and rear axle, adjustable by the driver via brake balance system

Derivative sensors & harness for retrofitting an ABS system

Front axle:

- Six-piston aluminium racing calipers in mono-bloc design with anti-knock-back piston springs
- Ventilated and grooved steel brake disc 380 mm diameter with aluminium disc bell
- Racing brake pads
- Optimized ventilation routing

Rear axle:

- Four-piston aluminium racing calipers in mono-bloc design with “anti-knock-back” piston springs
- Ventilated and grooved steel brake disc 380 mm diameter with aluminium disc bell
- Racing brake pads
- Optimized ventilation routing

Only ABS version master brake cylinders are permitted for the two brake circuits on the

– Front axle:

- (diameter: 17.8 mm, part number: 991.355.170.8C or 991.355.170.8E) and

– Rear axle:

- (diameter: 17.8 mm, part number: 991.355.170.8C or 991.355.170.8E).

Front axle:

- Aluminium 6-piston fixed calipers, one piece

FL: 991.351.427.8A

FR: 991.351.428.8A

- Internally vented brake discs, diameter = 380 mm, 32 mm thick, part number:

- FL: 991.351.105.8A
- FR: 991.351.106.8A

– Racing brake pads, part number: 991.351.942.8A (sprint version)

Rear axle:

– Aluminium 4-piston fixed calipers, one piece, parts number:

FL: 991.352.427.8A

FR: 991.352.428.8A

– Internally vented brake discs, diameter = 380 mm, 30 mm thick, part number:

FL: 991.352.107.8A

FR: 991.352.108.8A

– Racing brake pads, part number: 991.352.942.8A (sprint version)

A knock-back spring must be installed in each case under each brake piston of all brake calipers. External thermal or chemical treatment of these springs is prohibited. Only the following parts are permitted to be used:

Part number:

Front axle: 991.351.963.8A

Rear axle: 991.352.963.8A

3.5.2 - ABS System

The use of any system functioning as an ABS system is allowed. All Cars competing in Group 991.2 are allowed to be equipped with the Bosch Motorsport ABS system M5. The ABS system must not be modified in any way. All genuine parts must be retained and can only be replaced by identical parts. These parts are stated in the Porsche 911 GT3 Cup (Type 991.2) parts catalogue as released on the Porsche Motorsport Racecar Service Information (PMRSI). The use of the master brake cylinder with Porsche part nr 991.355.170.8E is mandatory. It is allowed to equip the brake caliper lines with quick connectors.

3.6 - Steering (steering wheel/hub extension)

The position of the steering rack on the front axle control arm is determined by spacer washers with a thickness of 8.5 mm (part number left: 991.341.613.7B; part number right: 991.341.613.8A).

Only one hub extension providing 20mm extension that is of the original Porsche Part number 997.347.287.90 is allowed.

The standard longitudinal and height adjustment facility is permitted to be used.

Line 991.347.775.8A of the steering gear may be equipped with a vibration damper 8K0.611.797.E or alternatively 8K0.611.797.F, see delivery condition.

3.7 - Wheel suspension

3.7.1 - General description front axle

McPherson suspension strut, adjustable in height, wheel camber and track

Forged struts:

Optimized stiffness

Double shear track rod connection

Heavy-duty spherical bearings

Wheel hubs with centre lock

Racing shock absorbers, non-adjustable

Forged & adjustable top mounts

Double-blade-type anti-roll bar

Electrohydraulic power steering with external control function for easy car manoeuvring.

Tire pressure monitoring system

3.7.2 - General description rear axle

Multilink rear suspension, adjustable in height, wheel camber and track

Forged struts

Optimized stiffness

Double shear track rod connection

Heavy-duty spherical bearings

Wheel hubs with centre lock

Racing shock absorbers, non-adjustable

Forged top mounts

Double-blade-type anti-roll bar

Tire pressure monitoring system

3.7.3 - Allowed adjustments

The suspension is permitted to be modified within the scope of the specified setting range.

All genuine parts must be retained. The maximum permissible thicknesses of the spacer washers in the front and rear axle control arms are:

Front axle: 18.0 mm

Rear axle: 15.0 mm

A change to the maximum permissible combined thickness of the spacer washers in the front and rear axle control arms can be announced by bulletin at any time before or during any event.

Furthermore, it is optional to fix the camber shims with aluminium tape.

The trailing arm axle bearing points of the front and rear control arms must be left in the position in which they are delivered. Additionally, the screw positions of the trailing arms at the wishbone bearing points may not be modified (see Attachment 4).

The wheelbase on the left and right sides of the car must be 2,456 mm +/-15 mm.

The measuring points are the centres of the wheel hubs.

3.7.4 - Anti-roll bars

The anti-roll bars are only permitted to be unhooked provided that no parts are removed in the process. Only the setting options for which the technical specifications have been provided are permitted to be used.

Shims are permitted to be used to compensate for the axial clearance of the anti-roll bars on the front and rear axles. These are available in the following versions:

1 mm with the spare part number 991.343.761.8A

2 mm with the spare part number 991.343.761.8B

Other shims or methods for axial clearance compensation must not be used. The overall axial clearance must not be less than 0,2 mm.

3.7.5 - Shock absorbers/springs

Only the factory-installed type Sachs shock absorbers and H&R chassis springs in their original condition are permitted to be used. The following number is stamped on the bump stops of the rear vibration dampers: 0049 5111 0 250. The original delivery condition of the bump stops of the front and rear dampers must not be modified in any way.

Vibration damper

Front: 991.343.045.8D

Rear: 991.333.051.8A

Bump stop

Front: 991.343.677.8A

Rear: 991.333.677.8A

Main spring

Front (240 N/mm): 991.343.531.8C

Rear (260 N/mm): 991.333.531.8C

Helper spring

Front (75/60/45): 996.343.537.90

Rear (80/60/60): 997.333.537.90

3.8 - Wheels (flange + rim) and tyres

3.8.1 - General description

Single-piece light-alloy rims according to Porsche specification and design with centre lock.

Front axle: 10.5J x 18 ET 28

Treaded Michelin transportation tires;

tire size: 27/65-18

Rear axle: 10.5J x 18 ET53

Treaded Michelin transportation tires;

tire size: 31/71-18

3.8.2 - Wheels

The use of any other wheels than the originally specified wheels is prohibited. All wheels must be fitted with original tyre pressure and temperature sensors.

From the moment that the car leaves the team's (Entrant) tent or garage to attend a qualifying or race until the end of Parc Fermé held after the session, all wheel valve caps must be used.

Only the use of valve caps mentioned in the respective spare parts catalogue is allowed and strictly enforced for all races.

The rims are permitted to be painted. It is prohibited to paint or treat any functional surfaces (areas highlighted in attachment 5).

Wheel rims are not permitted to be repaired. The friction strips on the inside of the rim must stay functional and must not be treated in any way.

3.8.3 - Tyres



For all events and Official Tests, only the version of Michelin tyres approved for the PSCI, with the following specification are allowed to be used.

Slick tyres

Front: 27/65 R 18 Porsche Cup N2

Rear: 31/71 R 18 Porsche Cup N2

Rain tyres

Front: 27/65 R 18 P2L

Rear: 31/71 R 18 P2L

Above mentioned tyres must be compulsorily equipped with the marking of the official distributor.

Tyres for qualifying and races of each event must be collected at the circuit from designated Michelin supplier.

The number of tyres permitted for each car entered to each event is defined by art 25.3 of the Sporting Regulations.

Porsche AG suggests that all competitors follow the recommendations and instructions of Michelin regarding tyre pressures and set-up. Only atmospheric air is permitted to be used to inflate the tyres. It is not permissible to rotate the tyres on the rims. It is permitted to refit tyres, but the refitting must be performed by the official Michelin tyre supplier (Neumáticos Álvarez).

Should the tyre manufacturer prescribe a rotational direction for its tyres, then any departure from the manufacturer's recommendation is prohibited.

3.8.4 - Tyre damage

If a marked tyre is damaged during qualifying or in a race, should the entrant wish to change the tyre then he must notify the Technical Scrutineers up to a maximum of two hours after the end of the Parc Fermé. Damaged tyres can only be exchanged with the approval of the Technical Scrutineers and in agreement with Michelin. The Technical Scrutineers have the authority to declare damaged tyres as unsafe and insist that they are replaced. In this case, marking of the tyres by the Technical Scrutineers is necessary.

If more than one tyre needs to be replaced throughout the duration of an event, the relevant car/driver will start from the last position on the starting grid (means only the replacement of one single tyre is permitted throughout a complete race weekend without a penalty). The Stewards will make the final decision regarding the severity of punishment. The cars that qualified behind the respective penalised driver will move up the grid by one position. If several cars are subject to the above rule, the corresponding cars/drivers will be lined up at the back of the starting grid in the order of their qualifying results. This applies for slick as well as rain tyres.

3.8.5 - Treatment

Any chemical, mechanical or thermal treatment of the tyres is prohibited. Cleaning of the rims is permitted. The mechanical removal of rubber abrasion and stones is permitted. The usage of heat guns or any similar devices of any kind to help the removal of rubber abrasion and stones ("tyre scraping") is prohibited.

The use of heated covers, materials or other means that change the temperature of the tyres is prohibited for the entire duration of an event.

From the start of the pre-grid until the end of the session, marked tyres are not permitted to be covered. This also applies for rain tyres (unmarked) available for use.

3.8.6 - Tyre logs

All barcodes of the marked tyres will be recorded in lists, the so-called tyre logs, which will be handed over to the competitors. The competitors must compare the barcodes of the tyres with those of the tyre logs and sign to confirm agreement.

All tyre logs must be presented signed to the Technical Scrutineers before the start of the respective session for which the tyres are permitted to be used.

No tyre is permitted to be used that is not listed on a signed tyre log that has been handed over to the Technical Scrutineers before the respective session.

3.9 - Bodywork and dimensions

3.9.1 - General description

Lightweight bodywork with smart aluminium-steel composite construction

Welded-in roll cage, in compliance with FIA Homologation Regulations for safety cages

Front bonnet with two air intake ducts for cockpit ventilation and quick release fasteners

Removable roof section in compliance with the latest FIA safety regulations

Pre-equipped fixation point for centre safety net attachment

Pickup point for lifting device

Modified and widened 911 GT3 fenders

Modified rear wheel arches

Modified and widened 911 GT3 front-end with spoiler lip

Modified 911 GT3 rear-end with integrated rain light, in compliance with FIA Homologation Regulations

Lightweight exterior:

CFRP (Carbon Fibre Reinforced Plastic) doors with sport-design rear-view mirrors

CFRP (Carbon Fibre Reinforced Plastic) rear engine lid with quick release fasteners

CFRP (Carbon Fibre Reinforced Plastic) adjustable rear wing (9 positions) part number 991.512.892.8A or 991.512.892.8D (Identified by Porsche part number 991.512.992.8D on the attachment to the left wing support) or 9F0.827.837.D.

Polycarbonate door windows and rear side windows with ventilation openings

Polycarbonate rear window

Rear underfloor with NACA ducts for brake and driveshaft cooling

Modified 911 cockpit:

Magnesium sub-frame in light weight design

Ergonomic driver-oriented centre console

Switch mask with fluorescent lettering

Steering wheel with quick release coupling, control panel and shift paddles

Adjustable steering column with steering angle sensor

Race bucket seat with longitudinal adjustment:

Homologated to latest FIA requirements

Individual padding system (delivery with size M)

Shock absorbing roll cage safety cover for leg protection at drivers' foot well

Six-point racing safety harness

100 litre fuel cell (FT3 safety fuel cell) and Fuel-Cut-Off safety valve in accordance with FIA regulations

Built-in air jack system (three jacks) with valve mountable on both sides of the car

Water-based paint

Exterior: white C9A

Interior: white filler-coat, no clear-coat finish

3.9.2 - Overall car dimensions and overhangs

The overall length of the car is 4,577 mm.

Total width: 1,978 mm

Total height: 1,248 mm

The front overhang is 1,046 mm, measured from the middle of the wheel of the front axle to the leading edge of the car (first point in the direction of the longitudinal axis, incl. front lip).

The rear overhang is 1,075 mm measured from the middle of the wheel of the rear axle to the rear edge of the car (last point in the direction of the longitudinal axis, including the exhaust, rear wing excluded).

The wheelbase on the left and right sides of the car must be 2.456 mm +/-15 mm.

The measuring points are the centres of the wheel hubs

3.9.3 - External bodywork (including windows)

The delivery status of the bodywork must be preserved.

a) Underbody covers

Only front underbody cover 991.504.601.8B or succeeding part numbers are allowed to be used. Underbody cover 991.504.601.8A is not allowed to be used, even if the car was fitted with in on delivery. See attachment 6.

Additionally, the rear window must remain fixed with the original type of fixing at all times.

b) Radiator protection

The small cooling ducts of the side radiators need to be covered with a protection mesh as shown in the parts catalogue.

For this modification, Entrants may use parts 991.505.713.81 and 991.505.714.81 or modify original meshes of the side or mid radiators (991.505.714.80, 991.505.713.80 and 991.505.711.80) as shown in the attachment 7

Alternatively, fabricated mesh's as stated in Technical Information 13/2018 are allowed.

3.9.4 - Windscreen

In addition to the original part, windscreens of the 911 GT3 Cup MY 2013-2017 with the part number 991.541.911.00 are permitted to be used, as well as windscreens of the Porsche 911 GT3 road car with part number 9P1.845.011 and any index thereof (e.g. 9P1.845.011.B).

Original Porsche windscreens are identified by an imprinted symbol as shown in Attachment 8.

Heated windscreens with part number 991.541.111.8B are permitted. The windscreen is permitted to be connected to the electrical system of the car and the heating function is permitted to be used.

To protect the windscreen and as a safety measure, 'tear-off' screens are permitted to be attached to the windscreen. Fitting will be checked during technical scrutineering and must be removed where applicable on request of the Technical Scrutineers.

3.9.5 - Side and rear windows

Only the genuine Porsche 911 GT3 Cup side and rear windows in their original version are permissible.

3.9.6 - Cockpit

a) Seat

The adaption of the seat by removing of original Recaro seat padding or adding, is forbidden in the areas of the seat shown in green colour on the illustration of Attachment 9.

Only the substitution of original unmodified padding by another original unmodified padding in a different size is permitted.

Upholstery in the bottom part of the seat on top of the paddings shown in green (see illustration Attachment 9) is permitted, as long as the original padding is not modified or removed.

The areas shown in yellow colour on the illustration of Attachment 9 may be changed, removed or upholstered. Upholstery is permitted by using original Recaro paddings (with a maximum thickness at any point not exceeding 50 mm). A foamed seat insert, according to FIA Appendix J, Article 253-16, may be used as long as the insert is made of fireproof material, colored in black. The use or change is subject to approval by the Technical Scrutineers and by the PSCI Technical Manager.

The preferred supplier for padding components is the seat manufacturer (Recaro).

The original seat mounting (seat rails and bracket) must be retained and must not be modified.

b) Ventilation in the passenger compartment

Only the factory-fitted ventilation pipe (NACA-intake on the front opening hood) is permissible for cockpit ventilation. The ventilation of the windscreen must not be affected. For additional ventilation of the passenger compartment only the existing original ventilation openings in the rear back windows are permissible.

The dimension of the NACA-intake port on the driver's side is permitted to be changed by taping.

c) Safety nets

Every car must be equipped with the after-sales safety nets as specified in the valid spare parts catalogue Attachment 10 and mounted complying with the Dr. Ing. h.c. F. Porsche AG mounting instructions, as described in the Technical Manual

3.9.7 - Additional roof hatch accessories

The car has an opening in the roof in order to make using the KED system easier should it become necessary to rescue the driver.

The roof hatch is located directly above the driver; the dimensions of the opening are 565 x 475 mm.

The roof hatch is connected to the roof via 7 livelocks which must be accessible at all times (no foiling or painting of live locks is permitted).

3.9.8 - Ground clearance of car

The minimum ground clearance of the ready-to-drive car (with the driver in the car and slick tyres in compliance with Article 2.7, at 2.0 bar \pm 0.1 bar air pressure) must not be less than the specified dimension, as measured at the specified measuring points, at any time during the event.

For the entire duration of the event the ground clearance of the front axle is to be a minimum of 78.0 mm and the clearance at the rear axle a minimum of 100.0 mm.

The measuring points (see Attachment 11) at the front axle are the mounting bolts (M12x105) of the cross member/bodywork in relation to the reference surface. At the rear axle, the machined rear surface in the

direction of travel on the side section in relation to the reference surface. The ground clearance is permitted to be changed within the existing adjustment range.

From the Pre-Grid to the end of the Parc Fermé during qualifying session, any modification of the ground clearance of the car using the front spring rests is strictly forbidden.

3.9.8.1 - Measuring method

The minimum ground clearance of the ready-to-drive car is checked using a measuring plate and appropriate height gauges for the axle to be measured in each case. The measurement is checked with the ready-to-drive car incl. the driver on board, standing on the measuring plate. If the measuring gauges can be accessed under the measuring points described above, the requirement to comply with the minimum height is satisfied. Any measuring tolerances will be taken into account by the Technical Scrutineers.

The Technical Scrutineers may at any time in their absolute discretion check the ground clearance measurement with any set of tyres allocated to the respective start number used during the session that the check is performed during or after. The Technical Scrutineers may also use instruments such as calipers or depth gauges to determine the car ground clearance.

3.9.8.2 - Measurement location

The measurement is conducted on the measuring plate during technical scrutineering. The measuring plate is available to the participating teams to check the minimum ground clearance during this period after consultation with the Technical Scrutineers. A check can also be made in the pit lane for the duration of the qualifying session.

3.9.8.3 - Failure to reach minimum height

Failure to reach the minimum height during the qualifying session will be penalised with the cancellation of the times achieved by the driver concerned. The driver is permitted, however, to take up the race from the last place on the starting grid. Failure to reach the minimum height in the race will result in disqualification from the points classification for the race.

3.10 - Aerodynamic devices

The original position of the wing section is permitted to be changed within the specified scope for adjustment.

One strip of transparent adhesive tape (max. 80.0 mm long, 20.0 mm wide) is permitted as a fixing element on the front wheel covers at a 90° angle in relation to the particular gaps that are taped over.

Furthermore, competitors are permitted to tape over the full area of the headlight lenses with transparent Heli tape, without thereby taping over a slot in the bodywork.

Apart from the above, taping over of any slots in the bodywork, wings or other permanent parts, joints and openings is not permitted.

Any alteration or amendment outside the above set parameters will render the car non-compliant with the Technical Regulations and may be subject to penalties from the Stewards.

All cars must be equipped with air guide plates for the front fenders left and right-hand side (Attachment 12).

3.11 - Electrical equipment

a) General description

COSWORTH colour display ICD with integrated fault diagnosis

COSWORTH electrical system control unit IPS32

Electronic throttle system

Fire extinguishing system (extinguishing agent: gas)

Battery 12 V, 70 Ah (AGM), leak-proof, placed in the co-driver foot well

Alternator 175 A

Fan in light weight design

Wiper with direct drive (intermittent and high speed function)

Two additional switches in the centre console for additional power consumers

CAN connection (data logger, video system)

b) Lighting system:

Bi-xenon-headlight

LED daytime running light

LED rear lighting system and rain light in compliance with the latest FIA Homologation Regulation

Rain light

Porsche Motorsport informs that a new rain light is available for all Porsche 911 GT3 Cup (991.2) type cars. The rain light must be installed in the rear bumper. The rain light is mandatory since 01.01.2024 according to FIA standard 8874-2019 for international racing championships (article 277-II SH). Installation in accordance with the following instructions is a prerequisite for participation in relevant competitions.

Pos	Part number	Description	Quantity per car
1	9F2945195	RAIN LIGHT	1
2	9F0807286H	BRACKET	1
3	999.190.191.30	POP RIVET A 3.2X17.0	2
4	999.915.323.40	ADHESIVE DP 490	1
5		TEMPLATE	1

2 - Installation instructions and notes for use

See Attachment 13

Optionally, the usage of the following electrical equipment is permitted:

oil level indicator:

(1x 991.641.139.9A, bracket 1x 991.641.473.8A)

charging cable (1x 991.612.505.7A,

bracket 1x 991.611.731.7A, plug 1x 991.450.841.8A)

cockpit illumination (1x 991.641.577.8A/9F0947179)

starting number illumination: 1x 991.612.777.7A,

(with only the loom being permitted to stay in the car.)

It is not permitted at any time for any competitor to read any sensors with any equipment, which are not allocated to the competitor's own team. Any breach of this regulation may result in the competitor being disqualified from the relevant session, race, or competition.

3.12 - Fuel circuit

Only the fuel system permitted for the Porsche 911 GT3 Cup car of model year 2017, 2018 and 2019 is permitted to be installed.

Additionally, to the original fuel system, every car must be equipped with the after-sales defueling appliance consisting of the following parts:

- breakaway coupling:	2x 997.110.191.8C
- sealing washer:	2x 991.201.983.9A
- support washer:	2x WHT004800
- adapter piece:	1x 9F0201156
- drain hose:	1x 9F0201627
- clamp:	1x 90017101401

The running of the car using the service position of the fuel pumps is prohibited, unless there is a technical issue with the system. The system may not be used with any of the pumps switched to service position for more than one lap.

3.13 - Lubrication system

Lubricants

Engine:

Mobil 1 10W-40 engine oil is compulsory. All additives are prohibited.

Transmission:

Mobilube 1 SHC 75W-90 transmission oil is compulsory. All additives are prohibited. There must be a minimum of 2.7 litres of transmission oil in the gearbox at all times during the event.

3.14 - Data transfer

The use of radio-based information transmission in the vehicle (e. g. telemetry) is forbidden, the only exception is the usage of the built-in tyre pressure monitoring system, which uses radio transmission for its functionality.

It is forbidden to read any sensor value or data, with any equipment, from any car not belonging to the Competitor.

Only the Promoter may access the cars data through the approved marshalling system. All transmitted or recorded data shall be made available to Race Officials and to authorized third parties.

From the Pre-Grid to the end of the Parc Fermé during qualifying, only the PCCI Technical Manager and personnel nominated by the Promoter are permitted to connect laptops/computers to the cars.

Any infringement shall result in a penalty which will be levied by the Stewards

At no time during an event, external connection (also wireless) may be made between the car and any external equipment other than the cars equipment to read out the antennas of the tyre pressure monitoring system.

3.14.1 - Radio system (if applicable)

A radio system is allowed to fulfill the communication between driver and team members (Entrant). Radio system wiring loom must be properly fitted.

The choice of radio system (kind, manufactured, model, fixation) is free, but must be approved by the Promoter. Radio system installation needs to be done using metal hardware and be able withstand a crash of 30G.

Installation shall be approved by the Technical Scrutineers and by the PSCI Technical manager.

When mounting fixed speakers in the Driver's helmet, the FIA helmet regulations must be strictly observed. In the case of any ambiguity, the Driver/Competitor must produce proof that the components used are suitable for use in the car (fire prevention, etc.).

On written request by the competitor, the Promoter may authorise that a separate radio loom can be carried in the vehicle, providing it is completely electrically disconnected from the vehicle and does not interfere with or alter any function of the vehicle or the approved radio system. The installation of a separate radio loom must be approved by the Technical Scrutineers. The Promoter may withdraw such authorisation at any time during an event.

3.14.2 - Data Recording

Use of the factory-fitted data recording system manufactured by COSWORTH is compulsory. The COSWORTH system is assigned to the car's chassis number and must not be exchanged. Only the setups approved by Dr. Ing. h.c. F. Porsche AG and by the Promoter are permitted to be used for the duration of the event.

All recorded data relating to the free practice, qualifying or race must be made available to the Technical Scrutineers, the Promoter and their delegates.

Throughout the entire event, cars must be configured to recognize the lap timing using the infrared beacon receiver. A beacon transmitter will be placed on the pit wall by the Promoter.

Any additional electrical connection to the car's wiring harness is not permitted. Installations set up by the Promoter are exceptions to this rule, as well as the marshalling system wiring loom.

3.14.3 - Notes

Everything that is not expressly permitted in these Regulations is prohibited. Any addition or removal of material, heat treatment or coating to alter the properties of a part or component and/or its dimensions is forbidden. Mounting a part in a different way and/or location than the original delivery condition is forbidden. Any permitted changes may only serve the intended purpose. The decision of the Promoter shall be final regarding any interpretation of these Regulations. The Promoter reserves the right to amend and extend these rules (in consultation with the RFEDA).

4 – Common to both models

4.1 – Timing Transponder

Each team must equip their Car with a AMB transponder, for example from Mylaps.

The timing transponder must be mounted in the frontright wheel arch behind the front axle as shown underneath. Teams can buy a transponder and Driver ID from the organisation. The illustration below refers to all Cars. Consult the Series Technical Manager or Scrutineer if needed.

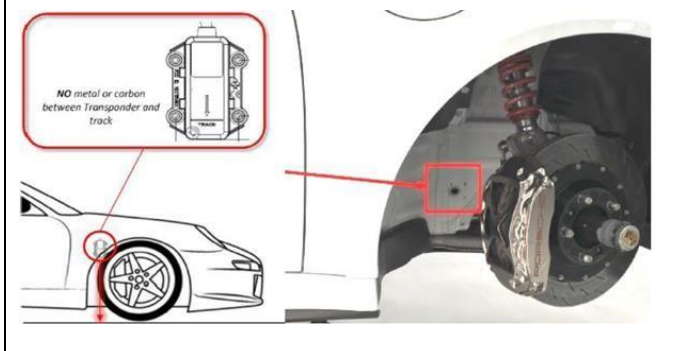
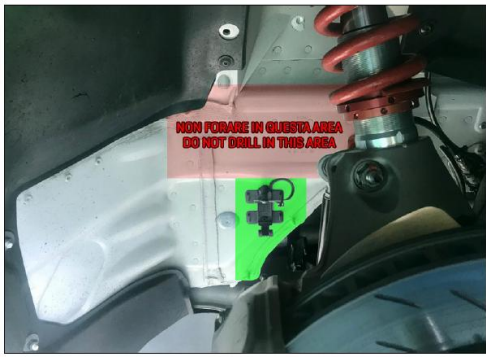
<p>991.1</p> 	<p>991.2</p> 
	<p>Standard timing beacon location - Front fender, right hand side, green area - The red area must not be drilled in any case.</p>

4.2 – Cameras

The installation of a camera system is recommended. This must be a ‘High Definition’ system. This installation will be checked by a member of the Technical Scrutineers. It is the responsibility of the Competitor to provide the equipment. Each Competitor needs to make sure each session is recorded and stored. We advise to foresee a spare memory card for in case one is confiscated for analysis. The PSCI is owner of the recorded videos and its copyrights. The videos can be used in private circumstances but can’t be distributed to third parties. The camera needs to be positioned in the centre of the Car. Mounted on the x-shaped tube of the roll cage behind the seat. The camera should be mounted in a way that it records the Driver and track in front of the Car. The illustration below refers to all Cars. Consult the Series Technical Manager or Scrutineer if needed.



Parts should be rigid. A keycord must be attached to the camera and roll cage. This to avoid a drop of the camera into the pedal box during an incident. Make sure that the keycord doesn’t block the view of the camera while braking. The use of mounting parts with suction cup are forbidden, with the exception when using a ‘Racelogic VBox’ System RLVBVDHD001P. The use of camera on the outside of the cockpit are prohibited.

ATTACHEMENTS

Attachment 1 – Ballast weights – 991.1 and 991.2

Ballast Position (Approved and Conforming ballast position)

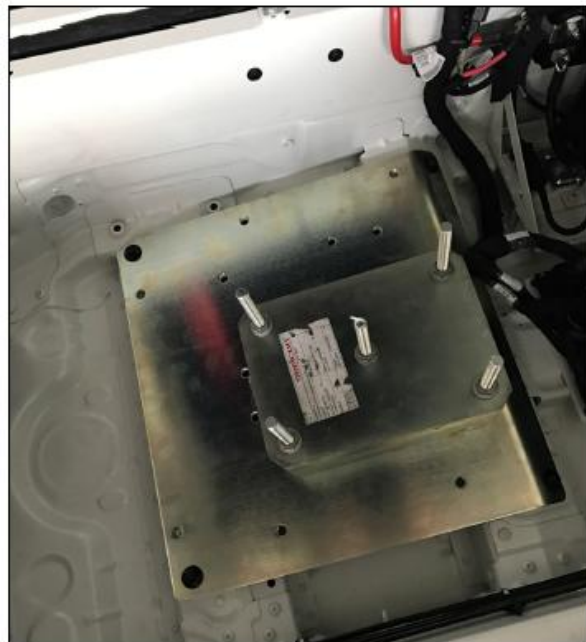
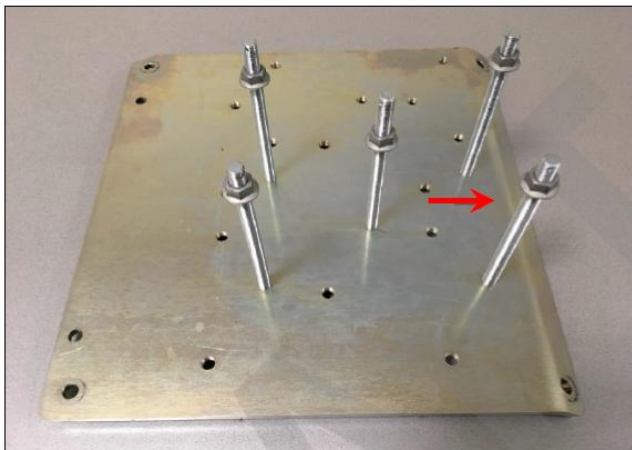
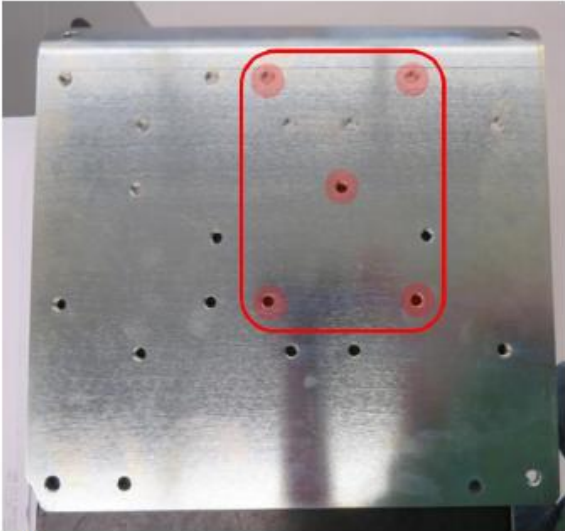

Attachment 5 – Differential lock ramp breakover angle (new graphic will be supplied) **ONLY FOR 991.1**

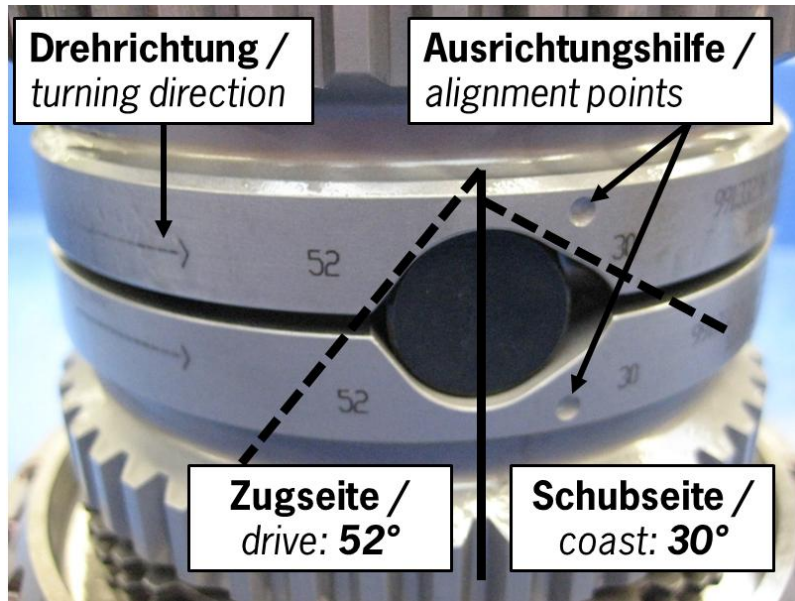

Attachment 6 – Differential design

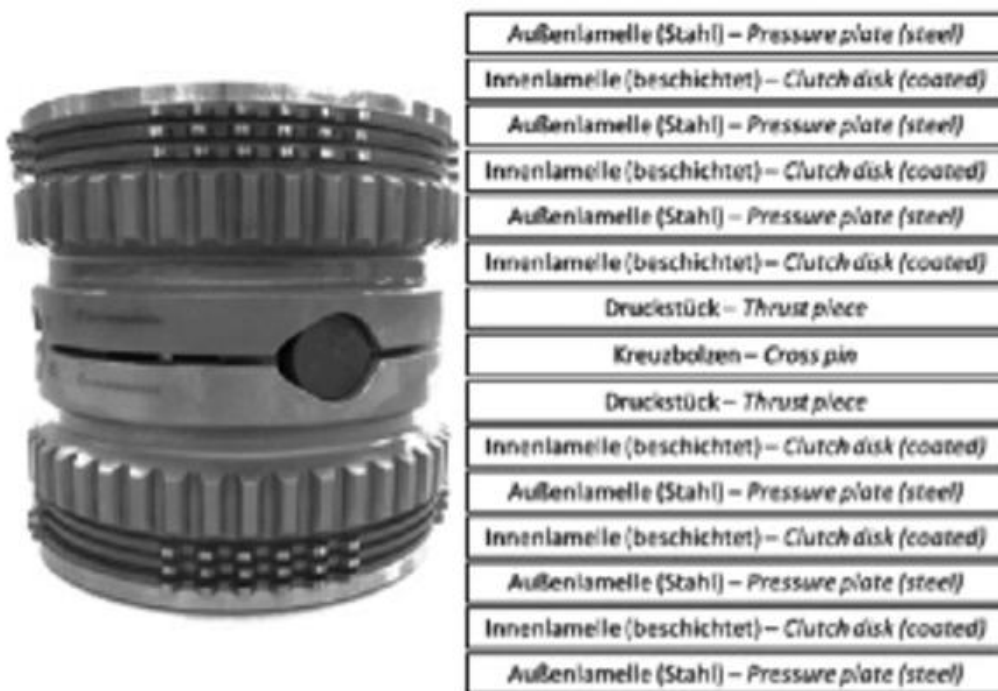

If MY 2013 differential housings are used, the shim may also be used to compensate for the central position of the cross pin.

Attachment 7 – Friction package configuration



Attachment 8 – Control arms

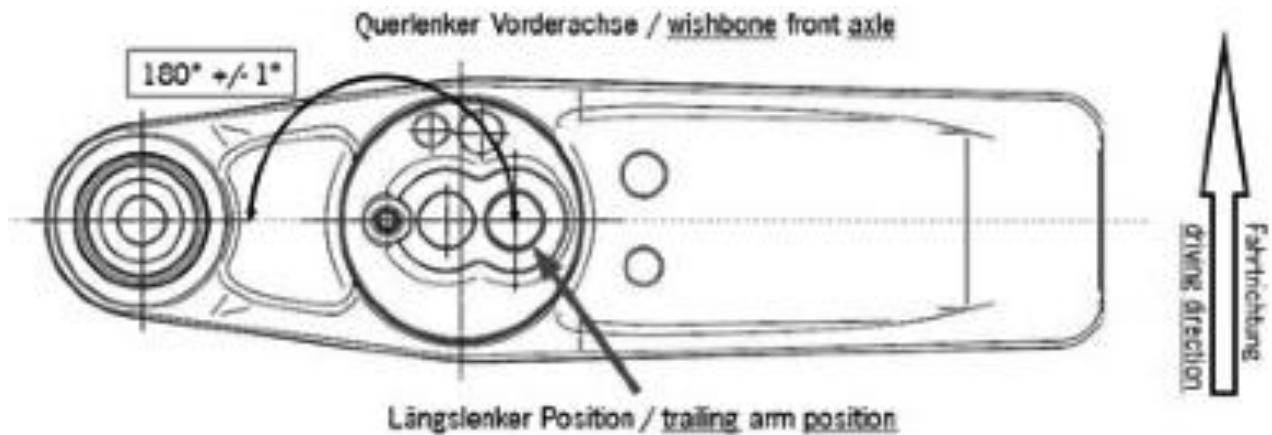

Attachment 9 – Minimum ground clearance, rear and front axle _991.1

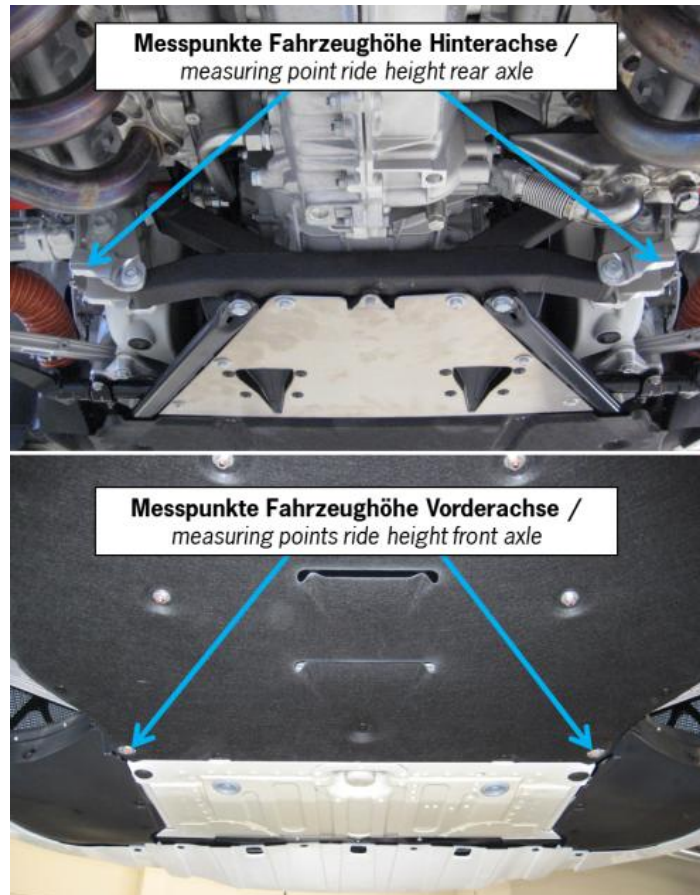

Table – Ground Clearance

Group	Car Type	MY	Front	Rear
991.1	Porsche 911 GT3 Cup, type 991.1	13 – 16	78mm	100mm

Table – max. permissible thicknesses of the spacer washers

Group	Car Type	MY	Front	Rear
991.1	Porsche 911 GT3 Cup, type 991.1	13 – 16	18,0 mm	15,0 mm



Attachment 11 – Holder for front silencer _991.1



Attachment 12 – Rain light

1 - Installation instructions and notes for use

To implement the following modification, the rear bodywork must be removed according to the instructions in the technical manual (chapter 4.5.17 rear apron).

To prepare for fitting the rain light, the template for the cutout in the rear bumper must be downloaded from PMRSI. Print the template on a sheet of DIN A4 paper – ensure that the print area scale is set to 100%. After printing the template, the measurements given in millimetres (mm) should be checked to ensure the scale is correct. Afterwards, precisely cut out both the template along the outer edges and the holes marked green

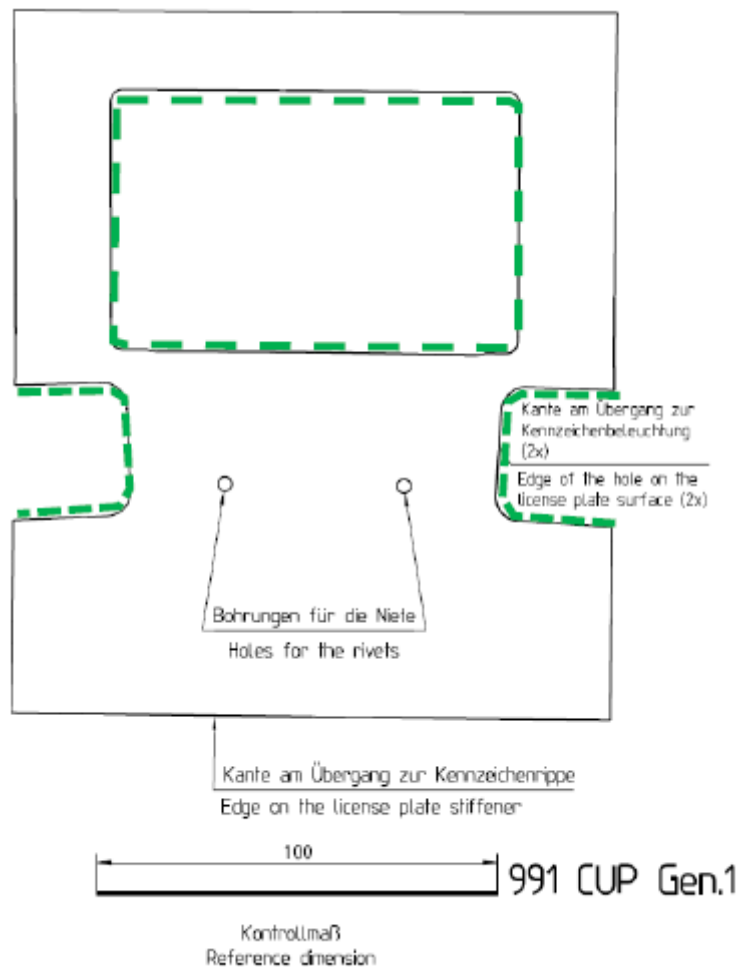

1 - Installation for Porsche 991 GT3 Cup (991.1)

A - Attach the template to the rear bumper

Align the template along the green marked edges of the three cutouts and the bottom row of the LED cut-outs of the old rain light and attach in place using adhesive tape.

Note: Aligning the template using only the two marks for the pop rivets will not guarantee that the template is positioned correctly.

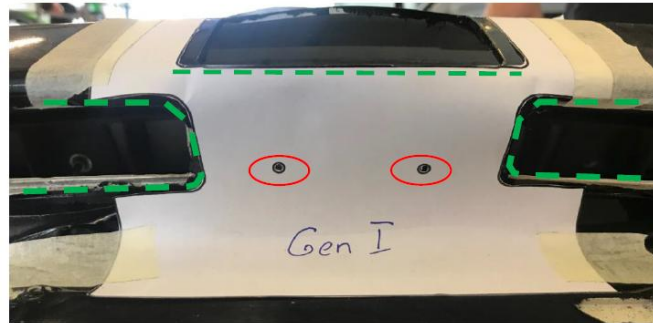

Afterwards use the template to mark the area on the rear bumper to be cut out. A white pen is recommended



2 - Rear bumper cut out

The following tools are recommended when making the rear bumper cutout:

Air saw with new, sharp blade

File

Air grinder / sander

After cutting out the marked areas ensure that the cut edges are free of burrs to ensure that the rain light fits exactly.

3 - Installing rain light

Bolt the rain light to the relevant bracket (bolt tightening torque 8 Nm). Grind the side lashes on the bracket and the bonding area on the rear bump using sandpaper (120 grit), then clean/degrease the areas with Isopropanol before applying DP 490 adhesive.



Attach the unit to the inner side of the rear bumper using the two pop rivets.



Allow the adhesive to cure for 24 hours before using the car again. After, reconnect the rain light cable to the main car loom and then follow the instructions in the technical manual (chapter 4.5.17 rear apron) to refit the rear bumper.

3 - Ordering parts

The parts are available via logistics@p21motorsport.com. If you have any technical question regarding this or any other technical information issued, please contact us by email: tech@p21motorsport.com.

Attachment 13 – Seat Padding

Homologation relevant: 5x paddings, must not be changed, removed or upholstered, available in three sizes

Not homologation relevant: 6x paddings, may be changed, removed or upholstered as well as replaced by a foamed seat insert, available in three sizes

Homologation relevant: 2x paddings, must not be changed or removed, Upholstery allowed

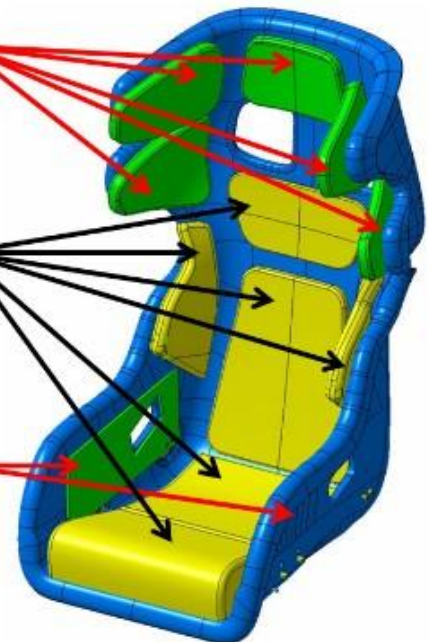

ONLY 991.2

Attachment 2 -- References of exhaust system parts

PORSCHE
MOTORSPORT
PORSCHE

2.5 Abgasanlage

Erstellungsdatum: 12.08.2019 Model 2018 2019 (Typ 991) 49

911 GT3 Cup

Fos.	Materialbezeichnung	M	St.	Material
1	Z ABGASKRUEMMER ZYL.1-3	X	1	99111302192
2	Z ABGASKRUEMMER ZYL.4-6	X	1	99111302292
3	LAMBDA-SONDE VORKAT	2		9A160618101
4	DICHTUNG ABGASKRUEMMER	2		9A111110790
5	6KT-MU M 8	18		99908464202
6	DICHTRING	2		98011156100
7	KUGELSCHELLE	2		99711133690
8	VERBINDUNGSROHR LINKS	X	1	9911115119A
9	VERBINDUNGSROHR RECHTS	X	1	9911115128A
10	FLANSCH	2		99711146390
11	DICHTRING	2		99711156390
12	6KT-MU M 8	13		99908464901
13	FLANSCH	X	2	9971114618A
14	DICHTRING	2		99711156190
15	Z ENDSCHALLDAEMPFER	1		99711102792
16	SPANNBAND SCHALLDAEMPFER	2		99711111970
17	ZYL-SHR AM8X50	2		90006736201
18	ABGASENDROHR	1		99111125395
19	SCHEIBE	1		99711175591
20	SCHEIBE	2		99711175391
21	HALTER ENDSCHALLDAEMPFER	X	1	9911114739B

Attachment 3 - Limited slip differential

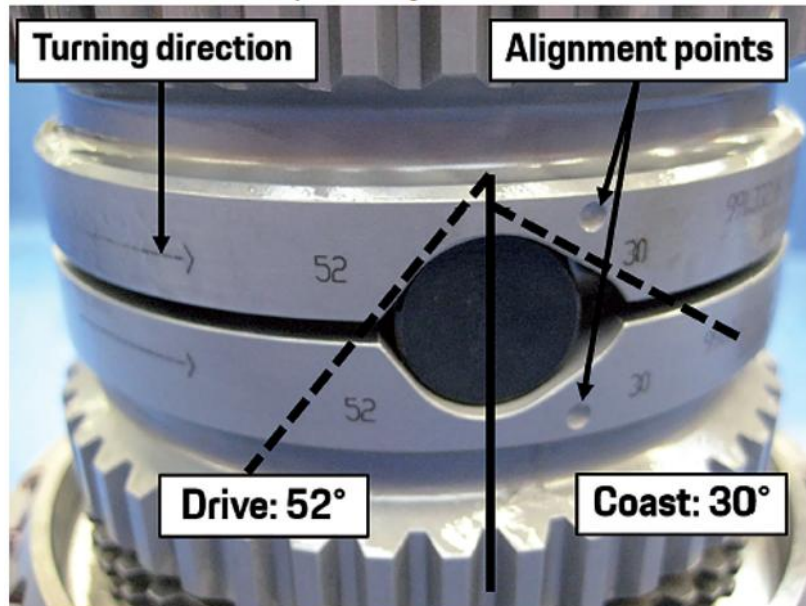

Attachment 3 – Authorised layout



- Belleville Spring
Disk Ring
- Pressure Plate
Clutch Disk
Pressure Plate
Clutch Disk
Pressure Plate
Clutch Disk
- Thrust Peace
Thrust Peace
- Clutch Disk
Pressure Plate
Clutch Disk
Pressure Plate
Clutch Disk
Pressure Plate
- Disk Ring
Belleville Spring



Attachment 4 – Control arms

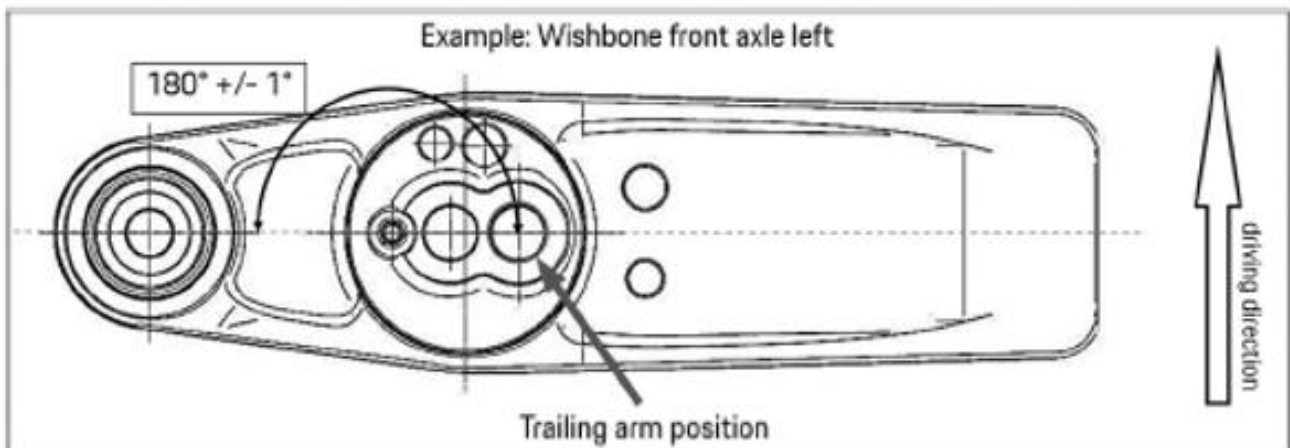

Attachment 5 – RIMS

991.504.601.8A - not allowed to be used



991.504.601.8B - allowed



Attachment 7 – Radiator protection

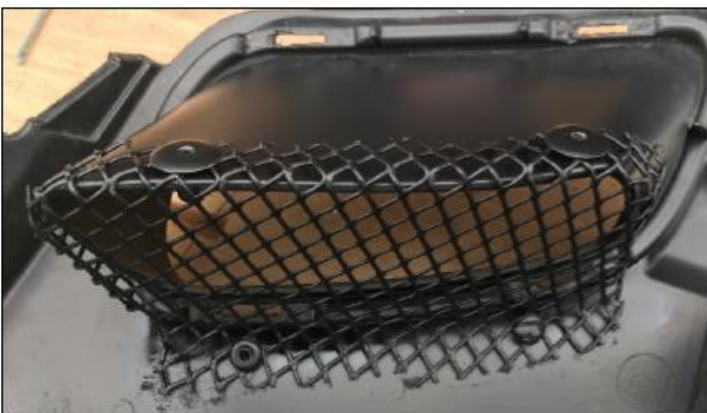
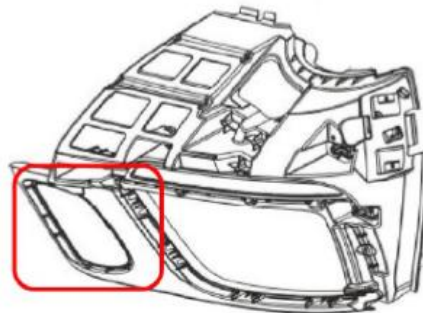
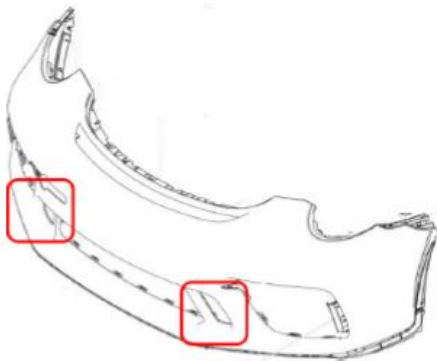

The mesh has to be fastened by rivets to the retaining frames of the front cover as shown in the picture.

Attachment 8 – Identification of original Porsche windscreens

All original Porsche windscreens can be identified by the Porsche logo (visible in the red square in the picture below) independently of their part number.



Attachment 9 – Seat Padding

Homologation relevant: 5x paddings, must not be changed, removed or upholstered, available in three sizes

Not homologation relevant: 6x paddings, may be changed, removed or upholstered as well as replaced by a foamed seat insert, available in three sizes

Homologation relevant: 2x paddings, must not be changed or removed, Upholstery allowed

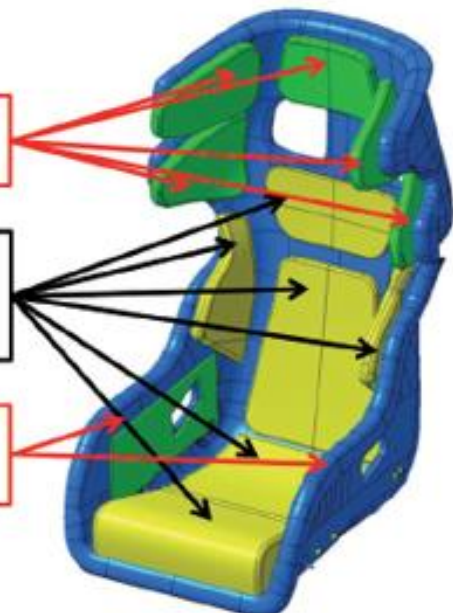

Attachment 10– Mandatory safety nets

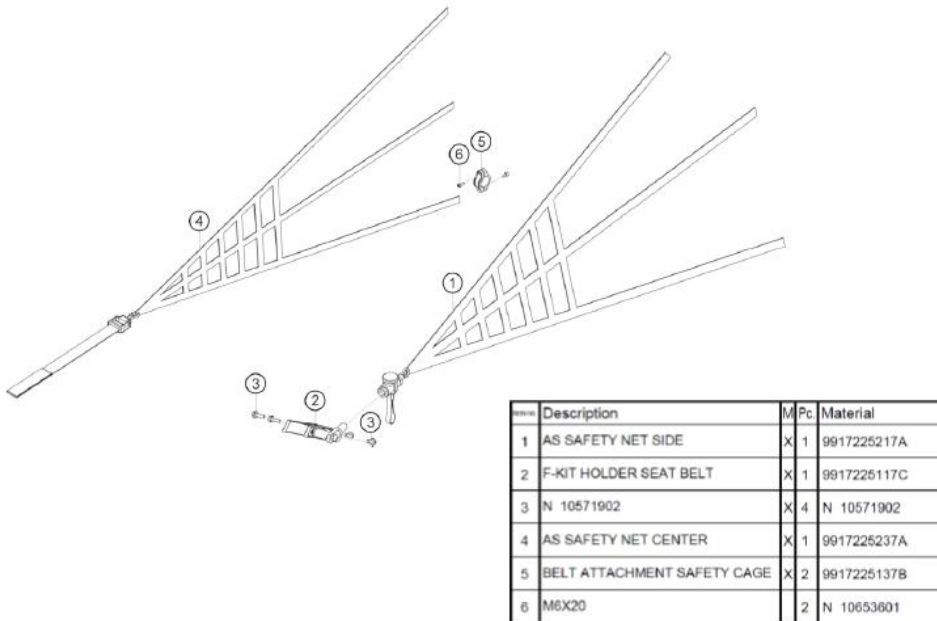

Attachment 11 – Minimum ground clearance, rear and front axle

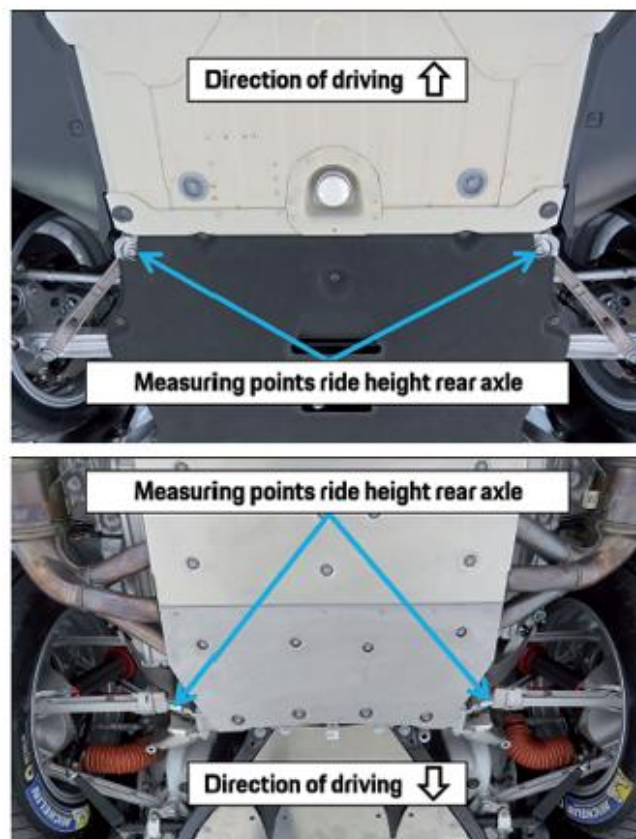

Attachment 12 – Standard air guide plates



Attachment 13 – Rain light

1 - Installation instructions and notes for use

To implement the following modification, the rear bodywork must be removed according to the instructions in the technical manual (chapter 4.5.17 rear apron).

To prepare for fitting the rain light, the template for the cutout in the rear bumper must be downloaded from PMRSI. Print the template on a sheet of DIN A4 paper – ensure that the print area scale is set to 100%. After printing the template, the measurements given in millimetres (mm) should be checked to ensure the scale is correct. Afterwards, precisely cut out both the template along the outer edges and the holes marked green

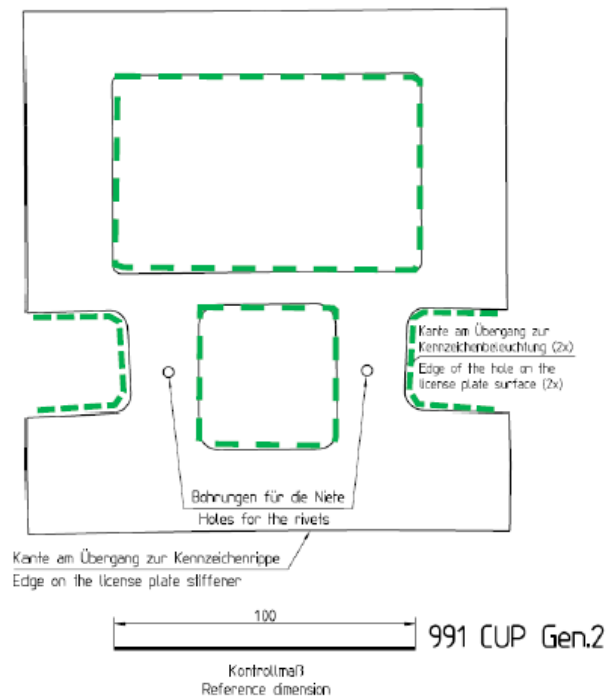

2.2 - Installation for Porsche 991 GT3 Cup (991.2)

1 - Attach the template to the rear bumper

Align the template along the green marked edges of the three cutouts and the bottom row of the LED cut-outs of the old rain light and attach in place using adhesive tape.

Note: Aligning the template using only the two marks for the pop rivets will not guarantee that the template is positioned correctly.

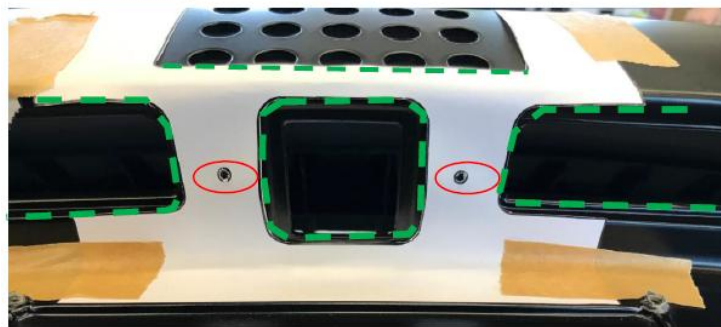

Afterwards use the template to mark the area on the rear bumper to be cut out. A white pen is recommended.



2 - Rear bumper cut out

The following tools are recommended when making the rear bumper cutout:

Air saw with new, sharp blade

File

Air grinder / sander

After cutting out the marked areas ensure that the cut edges are free of burrs to ensure



3 - Installing rain light

Bolt the rain light to the relevant bracket (bolt tightening torque 8 Nm). Grind the side lashes on the bracket and the bonding area on the rear bumper using sandpaper (120 grit), then clean/degrease the areas with Isopropanol before applying DP 490 adhesive.



Attach the unit to the inner side of the rear bumper using the two pop rivets. After, reconnect the rain light cable to the main car loom and then follow the instructions in the technical manual (chapter 4.5.17 rear apron) to refit the rear bumper.

3 - Ordering parts

The parts are available via logistics@p21motorsport.com. If you have any technical question regarding this or any other technical information issued, please contact us by email: tech@p21motorsport.com.

